

## DMOS Dual Full-Bridge PWM Motor Driver with Overcurrent Protection

### FEATURES AND BENEFITS

- Low  $R_{DS(ON)}$  outputs
- Internal mixed current decay mode
- Synchronous rectification for low power dissipation
- Internal UVLO
- Crossover-current protection
- 3.3 and 5 V compatible logic supply
- Thin profile QFN and TSSOP packages
- Thermal shutdown circuitry
- Short-to-ground protection
- Shorted load protection
- Low current Sleep mode,  $< 10 \mu A$

### PACKAGES:

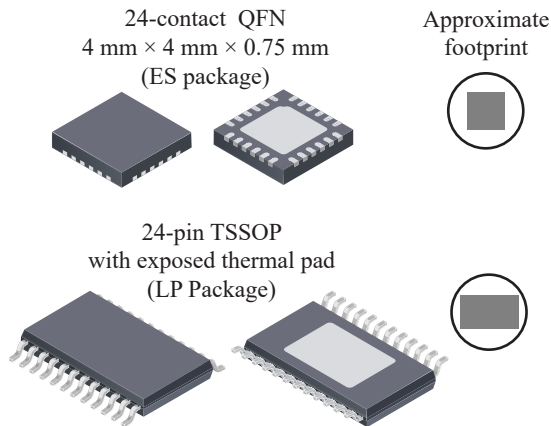

### DESCRIPTION

The A4986 is a dual DMOS full-bridge stepper motor driver with parallel input communication and overcurrent protection. Each full-bridge output is rated up to 35 V and  $\pm 2$  A.

The A4986 includes fixed off-time pulse width modulation (PWM) current regulators, along with 2-bit nonlinear DACs (digital-to-analog converters) that allow stepper motors to be controlled in full, half, and quarter steps. The PWM current regulator uses the Allegro™ patented mixed decay mode for reduced audible motor noise, increased step accuracy, and reduced power dissipation.

Internal synchronous rectification control circuitry is provided to improve power dissipation during PWM operation.

The outputs are protected from shorted load and short-to-ground events, which protect the driver and associated circuitry from thermal damage or flare-ups. Other protection features include thermal shutdown with hysteresis, undervoltage lockout (UVLO) and crossover current protection. Special power-up sequencing is not required.

The A4986 is supplied in a 24-contact QFN package (ES), and a 24-pin TSSOP package (LP) with an overall package height of  $\leq 1.2$  mm. Both packages have exposed pads for enhanced thermal dissipation and are lead (Pb) free (suffix -T), with 100% matte tin plated leadframes.

### Typical Application Diagram

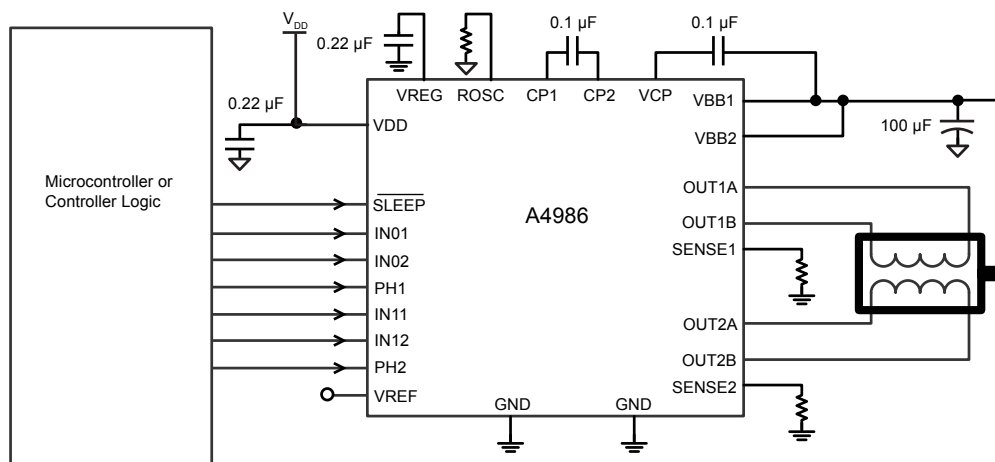

## SELECTION GUIDE

| Part Number  | Package                               | Packing                     |
|--------------|---------------------------------------|-----------------------------|
| A4986SESTR-T | 24-pin QFN with exposed thermal pad   | 1500 pieces per 7-in. reel  |
| A4986SLPTR-T | 24-pin TSSOP with exposed thermal pad | 4000 pieces per 13-in. reel |

## ABSOLUTE MAXIMUM RATINGS

| Characteristic                | Symbol       | Notes   | Rating      | Units |
|-------------------------------|--------------|---------|-------------|-------|
| Load Supply Voltage           | $V_{BB}$     |         | 35          | V     |
| Output Current                | $I_{OUT}$    |         | $\pm 2$     | A     |
| Logic Input Voltage           | $V_{IN}$     |         | -0.3 to 5.5 | V     |
| Logic Supply Voltage          | $V_{DD}$     |         | -0.3 to 5.5 | V     |
| Motor Outputs Voltage         |              |         | -2.0 to 37  | V     |
| Sense Voltage                 | $V_{SENSE}$  |         | -0.5 to 0.5 | V     |
| Reference Voltage             | $V_{REF}$    |         | 5.5         | V     |
| Operating Ambient Temperature | $T_A$        | Range S | -20 to 85   | °C    |
| Maximum Junction              | $T_{J(max)}$ |         | 150         | °C    |
| Storage Temperature           | $T_{stg}$    |         | -55 to 150  | °C    |

Functional Block Diagram

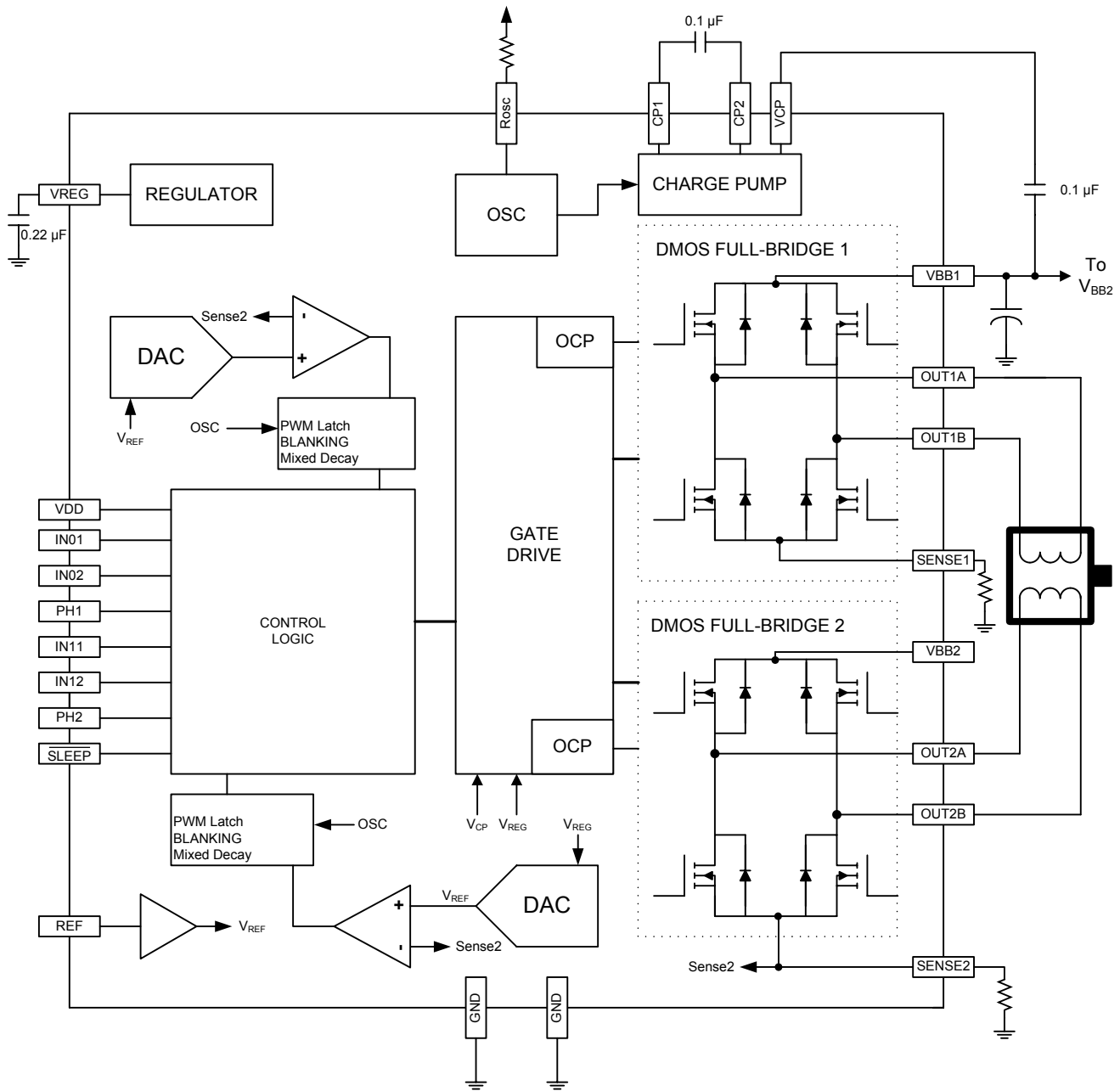

**ELECTRICAL CHARACTERISTICS [1]:** Valid at  $T_A = 25^\circ\text{C}$ ,  $V_{BB} = 35\text{ V}$  (unless otherwise noted)

| Characteristics                      | Symbol          | Test Conditions                                     | Min.                | Typ. [2] | Max.                | Units            |
|--------------------------------------|-----------------|-----------------------------------------------------|---------------------|----------|---------------------|------------------|
| <b>OUTPUT DRIVERS</b>                |                 |                                                     |                     |          |                     |                  |
| Load Supply Voltage Range            | $V_{BB}$        | Operating                                           | 8                   | –        | 35                  | V                |
|                                      |                 | During Sleep Mode                                   | 0                   | –        | 35                  | V                |
| Logic Supply Voltage Range           | $V_{DD}$        | Operating                                           | 3.0                 | –        | 5.5                 | V                |
| Output On Resistance                 | $R_{DSON}$      | Source Driver, $I_{OUT} = -1.5\text{ A}$            | –                   | 320      | 430                 | m $\Omega$       |
|                                      |                 | Sink Driver, $I_{OUT} = 1.5\text{ A}$               | –                   | 320      | 430                 | m $\Omega$       |
| Body Diode Forward Voltage           | $V_F$           | Source Diode, $I_F = -1.5\text{ A}$                 | –                   | –        | 1.3                 | V                |
|                                      |                 | Sink Diode, $I_F = 1.5\text{ A}$                    | –                   | –        | 1.3                 | V                |
| Motor Supply Current                 | $I_{BB}$        | $f_{PWM} < 50\text{ kHz}$                           | –                   | –        | 4                   | mA               |
|                                      |                 | Operating, outputs disabled                         | –                   | –        | 2                   | mA               |
|                                      |                 | Sleep Mode                                          | –                   | –        | 10                  | $\mu\text{A}$    |
| Logic Supply Current                 | $I_{DD}$        | $f_{PWM} < 50\text{ kHz}$                           | –                   | –        | 8                   | mA               |
|                                      |                 | Outputs off                                         | –                   | –        | 5                   | mA               |
|                                      |                 | Sleep Mode                                          | –                   | –        | 10                  | $\mu\text{A}$    |
| <b>CONTROL LOGIC</b>                 |                 |                                                     |                     |          |                     |                  |
| Logic Input Voltage                  | $V_{IN(1)}$     |                                                     | $V_{DD} \times 0.7$ | –        | –                   | V                |
|                                      | $V_{IN(0)}$     |                                                     | –                   | –        | $V_{DD} \times 0.3$ | V                |
| Logic Input Current                  | $I_{IN(1)}$     | $V_{IN} = V_{DD} \times 0.7$                        | –20                 | <1.0     | 20                  | $\mu\text{A}$    |
|                                      | $I_{IN(0)}$     | $V_{IN} = V_{DD} \times 0.3$                        | –20                 | <1.0     | 20                  | $\mu\text{A}$    |
| Logic Input Pull-down                | $R_{IN02}$      |                                                     | –                   | 100      | –                   | k $\Omega$       |
|                                      | $R_{IN12}$      |                                                     | –                   | 50       | –                   | k $\Omega$       |
| Logic Input Hysteresis               | $V_{HYS(IN)}$   | As a % of $V_{DD}$                                  | 5                   | 11       | 19                  | %                |
| Blank Time                           | $t_{BLANK}$     |                                                     | 0.7                 | 1        | 1.3                 | $\mu\text{s}$    |
| Fixed Off-Time                       | $t_{OFF}$       | OSC = $V_{DD}$ or GND                               | 20                  | 30       | 40                  | $\mu\text{s}$    |
|                                      |                 | $R_{OSC} = 25\text{ k}\Omega$                       | 23                  | 30       | 37                  | $\mu\text{s}$    |
| Reference Input Voltage Range        | $V_{REF}$       |                                                     | 0                   | –        | 4                   | V                |
| Reference Input Current              | $I_{REF}$       |                                                     | –3                  | 0        | 3                   | $\mu\text{A}$    |
| Current Trip-Level Error [3]         | $err_I$         | $V_{REF} = 2\text{ V}$ , % $I_{TripMAX} = 33.3\%$   | –                   | –        | $\pm 15$            | %                |
|                                      |                 | $V_{REF} = 2\text{ V}$ , % $I_{TripMAX} = 66.7\%$   | –                   | –        | $\pm 5$             | %                |
|                                      |                 | $V_{REF} = 2\text{ V}$ , % $I_{TripMAX} = 100.00\%$ | –                   | –        | $\pm 5$             | %                |
| Crossover Dead Time                  | $t_{DT}$        |                                                     | 100                 | 475      | 800                 | ns               |
| <b>PROTECTION</b>                    |                 |                                                     |                     |          |                     |                  |
| Overcurrent Protection Threshold [4] | $I_{OCPST}$     |                                                     | 2.1                 | –        | –                   | A                |
| Thermal Shutdown Temperature         | $T_{TSD}$       |                                                     | –                   | 165      | –                   | $^\circ\text{C}$ |
| Thermal Shutdown Hysteresis          | $T_{TSDHYS}$    |                                                     | –                   | 15       | –                   | $^\circ\text{C}$ |
| VDD Undervoltage Lockout             | $V_{DDUVLO}$    | $V_{DD}$ rising                                     | 2.7                 | 2.8      | 2.9                 | V                |
| VDD Undervoltage Hysteresis          | $V_{DDUVLOHYS}$ |                                                     | –                   | 90       | –                   | mV               |

[1] For input and output current specifications, negative current is defined as coming out of (sourcing) the specified device pin.

[2] Typical data are for initial design estimations only and assume optimum manufacturing and application conditions. Performance may vary for individual units, within the specified maximum and minimum limits.

[3]  $V_{ERR} = [(V_{REF}/8) - V_{SENSE}] / (V_{REF}/8)$ .

[4] Overcurrent protection (OCP) is tested at  $T_A = 25^\circ\text{C}$  in a restricted range and guaranteed by characterization.

### THERMAL CHARACTERISTICS: May require derating at maximum conditions

| Characteristic             | Symbol          | Test Conditions*                                               | Value | Units |
|----------------------------|-----------------|----------------------------------------------------------------|-------|-------|
| Package Thermal Resistance | $R_{\theta JA}$ | ES package; estimated, on 4-layer PCB, based on JEDEC standard | 37    | °C/W  |
|                            |                 | LP package; on 4-layer PCB, based on JEDEC standard            | 28    | °C/W  |

\*In still air. Additional thermal information available on Allegro website.

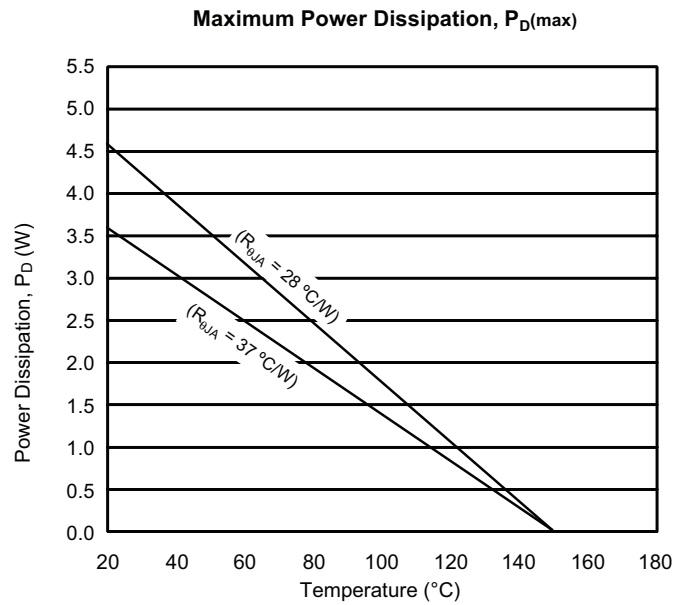

## FUNCTIONAL DESCRIPTION

**Device Operation.** The A4986 is designed to operate one stepper motor in full, half, or quarter step mode. The currents in each of the output full-bridges, all N-channel DMOS, are regulated with fixed off-time pulse width modulated (PWM) control circuitry. Each full-bridge peak current is set by the value of an external current sense resistor,  $R_{Sx}$ , and a reference voltage,  $V_{REFx}$ .

Percentages of the peak current are set using a 2-bit nonlinear DAC that programs 33%, 66%, or 100% of the peak current, or disables the outputs.

**Internal PWM Current Control.** Each full-bridge is controlled by a fixed off-time PWM current control circuit that limits the load current to a desired value,  $I_{TRIP}$ . Initially, a diagonal pair of source and sink FET outputs are enabled and current flows through the motor winding and the current sense resistor,  $R_{Sx}$ . When the voltage across  $R_{Sx}$  equals the DAC output voltage, the current sense comparator resets the PWM latch. The latch then turns off the sink and source FETs.

The maximum value of current limiting is set by the selection of  $R_{Sx}$  and the voltage at the VREF pin. The transconductance function is approximated by the maximum value of current limiting,  $I_{TripMAX}$  (A), which is set by

$$I_{TripMAX} = V_{REF} / (8 \times R_S)$$

where  $R_S$  is the resistance of the sense resistor ( $\Omega$ ) and  $V_{REF}$  is the input voltage on the REF pin (V).

The 2-bit DAC output reduces the  $V_{REF}$  output to the current sense comparator in precise steps, such that

$$I_{trip} = (\%I_{TripMAX} / 100) \times I_{TripMAX}$$

It is critical that the maximum rating (0.5 V) on the SENSE1 and SENSE2 pins is not exceeded.

**Fixed Off-Time.** The internal PWM current control circuitry uses a one-shot circuit to control the duration of time that the DMOS FETs remain off. The off-time,  $t_{OFF}$ , is determined by the

ROSC terminal. The ROSC terminal has two settings:

- ROSC tied to VDD or ground — off-time internally set to 30  $\mu$ s
- ROSC through a resistor to ground — off-time is determined by the following formula

$$t_{OFF} \approx R_{OSC} / 825$$

Where  $t_{OFF}$  is in  $\mu$ s.

**Blanking.** This function blanks the output of the current sense comparators when the outputs are switched by the internal current control circuitry. The comparator outputs are blanked to prevent false overcurrent detection due to reverse recovery currents of the clamp diodes, and switching transients related to the capacitance of the load. The blank time,  $t_{BLANK}$  ( $\mu$ s), is approximately

$$t_{BLANK} \approx 1 \mu s$$

#### Shorted-Load and Short-to-Ground Protection.

If the motor leads are shorted together, or if one of the leads is shorted to ground, the driver will protect itself by sensing the overcurrent event and disabling the driver that is shorted, protecting the device from damage. In the case of a short-to-ground, the device will remain disabled (latched) until the  $\overline{SLEEP}$  input goes high or VDD power is removed. A short-to-ground overcurrent event is shown in figure 1.

When the two outputs are shorted together, the current path is through the sense resistor. After the blanking time ( $\approx 1 \mu$ s) expires, the sense resistor voltage is exceeding its trip value, due to the overcurrent condition that exists. This causes the driver to go into a fixed off-time cycle. After the fixed off-time expires the driver turns on again and the process repeats. In this condition the driver is completely protected against overcurrent events, but the short is repetitive with a period equal to the fixed off-time of the driver. This condition is shown in figure 2.

If the driver is operating in Mixed decay mode, it is normal for the positive current to spike, due to the bridge going in the forward direction and also in the negative direction, as a result of the direction change implemented by the Mixed decay feature. This is shown in figure 3. In both instances the overcurrent circuitry is protecting the driver and prevents damage to the device.

**Charge Pump (CP1 and CP2).** The charge pump is used to generate a gate supply greater than that of VBB for driving the

source-side FET gates. A 0.1  $\mu\text{F}$  ceramic capacitor, should be connected between CP1 and CP2. In addition, a 0.1  $\mu\text{F}$  ceramic capacitor is required between VCP and VBB, to act as a reservoir for operating the high-side FET gates.

Capacitor values should be Class 2 dielectric  $\pm 15\%$  maximum, or tolerance R, according to EIA (Electronic Industries Alliance) specifications.

**V<sub>REG</sub> (VREG).** This internally generated voltage is used to operate the sink-side FET outputs. The nominal output voltage of the VREG terminal is 7 V. The VREG pin must be decoupled with a 0.22  $\mu\text{F}$  ceramic capacitor to ground. V<sub>REG</sub> is internally monitored. In the case of a fault condition, the FET outputs of the A4986 are disabled.

Capacitor values should be Class 2 dielectric  $\pm 15\%$  maximum, or tolerance R, according to EIA (Electronic Industries Alliance) specifications.

**Shutdown.** In the event of a fault, overtemperature (excess  $T_J$ ) or an undervoltage (on VCP), the FET outputs of the A4986 are disabled until the fault condition is removed. At power-on, the UVLO (undervoltage lockout) circuit disables the FET outputs and resets the translator to the Home state.

**Sleep Mode (SLEEP).** To minimize power consumption when the motor is not in use, this input disables much of the internal circuitry including the output FETs, current regulator, and charge pump. A logic low on the SLEEP pin puts the A4986 into Sleep mode. When emerging from Sleep mode, in order to allow the charge pump to stabilize, provide a delay of 1 ms before issuing a logic command.

**Mixed Decay Operation.** The bridge operates in Mixed Decay mode, as shown in figures 5 through 7. As the trip point is reached, the A4986 initially goes into a fast decay mode for 31.25% of the off-time,  $t_{OFF}$ . After that, it switches to Slow Decay mode for the remainder of  $t_{OFF}$ . A timing diagram for this feature appears in figure 4.

**Synchronous Rectification.** When a PWM-off cycle is triggered by an internal fixed-off time cycle, load current recirculates in Mixed Decay mode. This synchronous rectification feature turns on the appropriate FETs during current decay, and effectively shorts out the body diodes with the low FET  $R_{DS(ON)}$ . This reduces power dissipation significantly and can eliminate the need for external Schottky diodes in many applications. Synchronous rectification turns off when the load current approaches zero (0 A), preventing reversal of the load current.

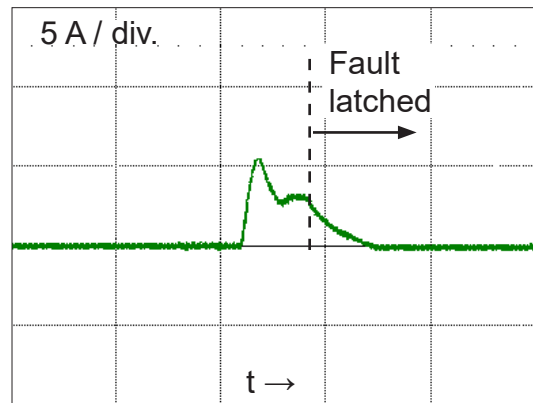

Figure 1. Short-to-ground event

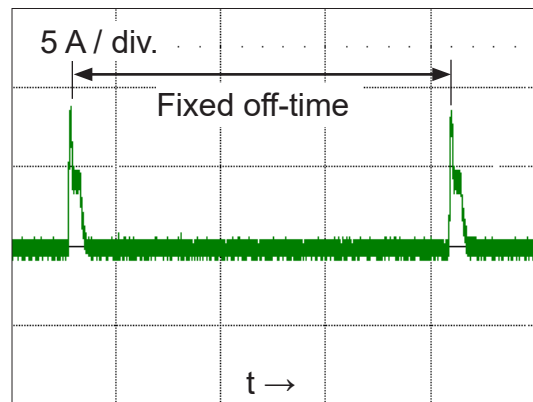

Figure 2. Shorted load (OUTxA → OUTxB) in Slow decay mode

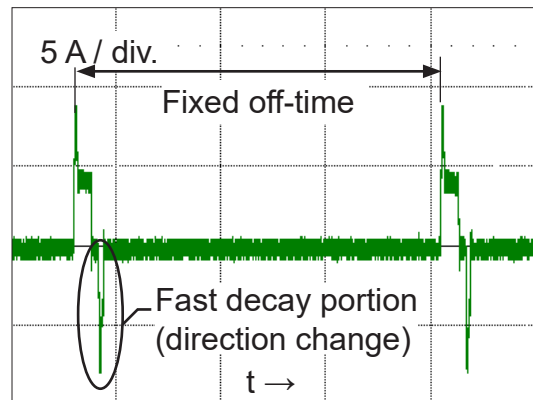
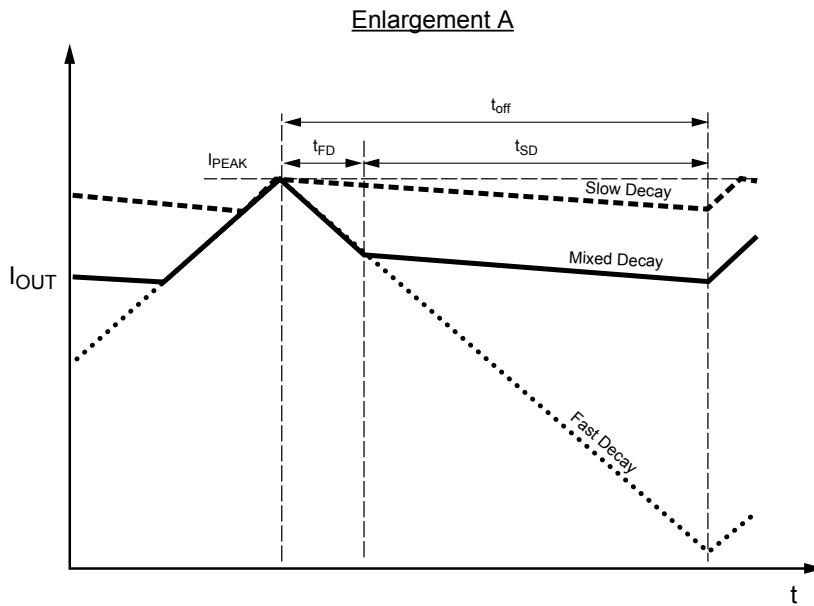
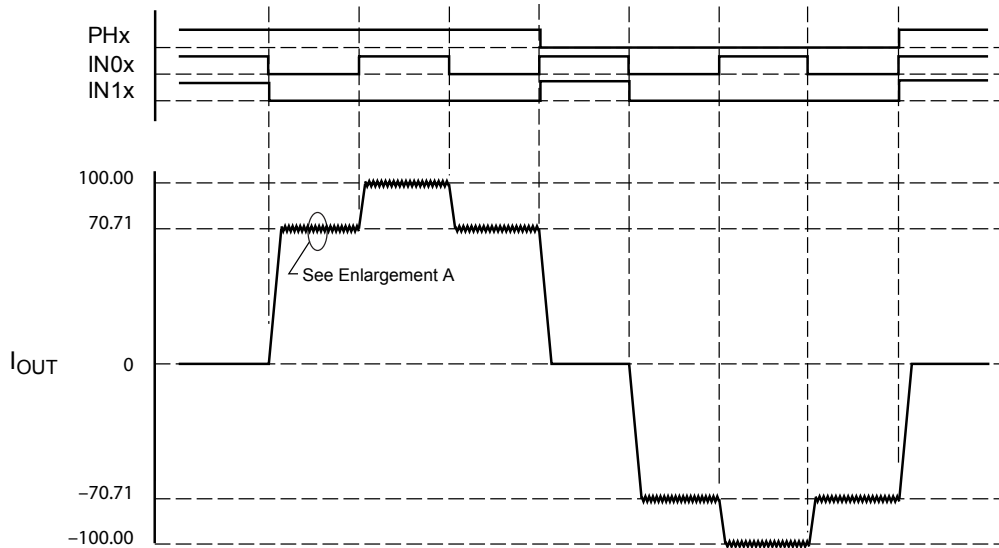

Figure 3. Shorted load (OUTxA → OUTxB) in Mixed decay mode



| Symbol            | Characteristic         |
|-------------------|------------------------|
| t <sub>off</sub>  | Device fixed off-time  |
| I <sub>PEAK</sub> | Maximum output current |
| t <sub>SD</sub>   | Slow decay interval    |
| t <sub>FD</sub>   | Fast decay interval    |
| I <sub>OUT</sub>  | Device output current  |

Figure 4. Current Decay Modes Timing Chart



## APPLICATION LAYOUT

**Layout.** The printed circuit board should use a heavy ground-plane. For optimum electrical and thermal performance, the A4986 must be soldered directly onto the board. On the underside of the A4986 package is an exposed pad, which provides a path for enhanced thermal dissipation. The thermal pad should be soldered directly to an exposed surface on the PCB. Thermal vias are used to transfer heat to other layers of the PCB.

In order to minimize the effects of ground bounce and offset issues, it is important to have a low impedance single-point ground, known as a *star ground*, located very close to the device. By making the connection between the pad and the ground plane directly under the A4986, that area becomes an ideal location for a star ground point. A low impedance ground will prevent ground bounce during high current operation and ensure that the supply voltage remains stable at the input terminal.

The two input capacitors should be placed in parallel, and as close to the device supply pins as possible. The ceramic capacitor (CIN1) should be closer to the pins than the bulk capacitor (CIN2). This is necessary because the ceramic capacitor will be responsible for delivering the high frequency current components. The sense resistors,  $R_{Sx}$ , should have a very low impedance path to ground, because they must carry a large current while supporting very accurate voltage measurements by the current sense comparators. Long ground traces will cause additional voltage drops, adversely affecting the ability of the comparators to accurately measure the current in the windings. The SENSEx pins have very short traces to the  $R_{Sx}$  resistors and very thick, low impedance traces directly to the star ground underneath the device. If possible, there should be no other components on the sense circuits.

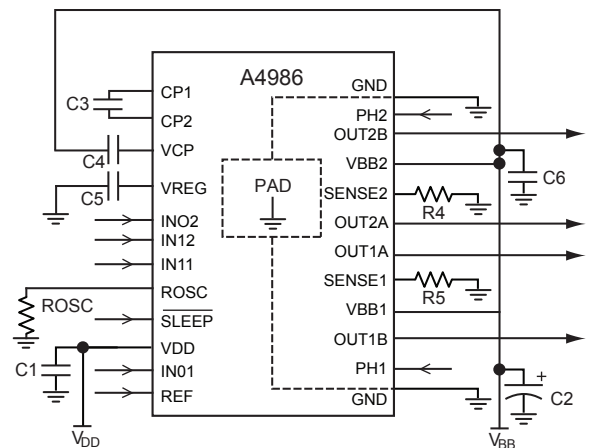
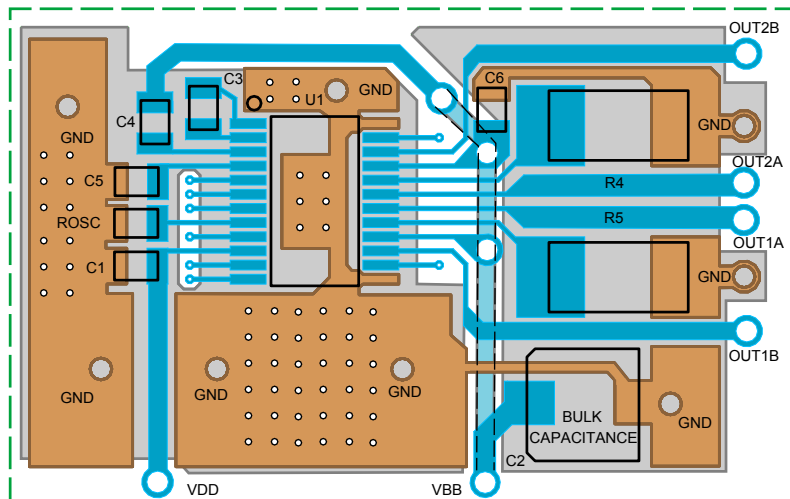
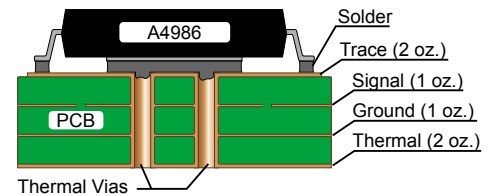

LP package configuration

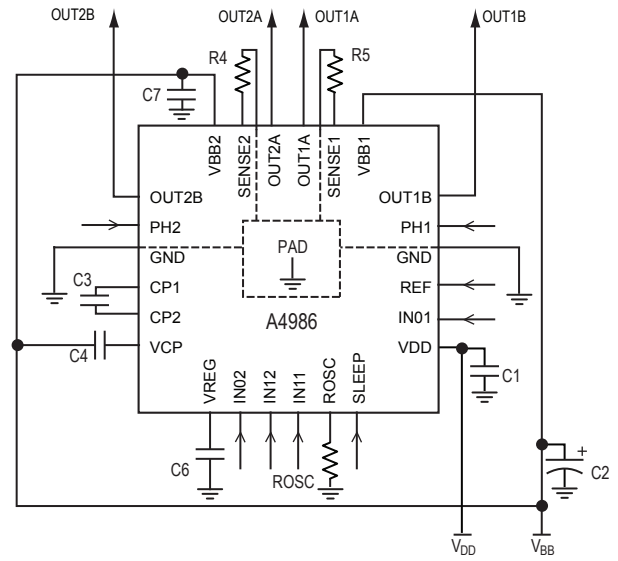
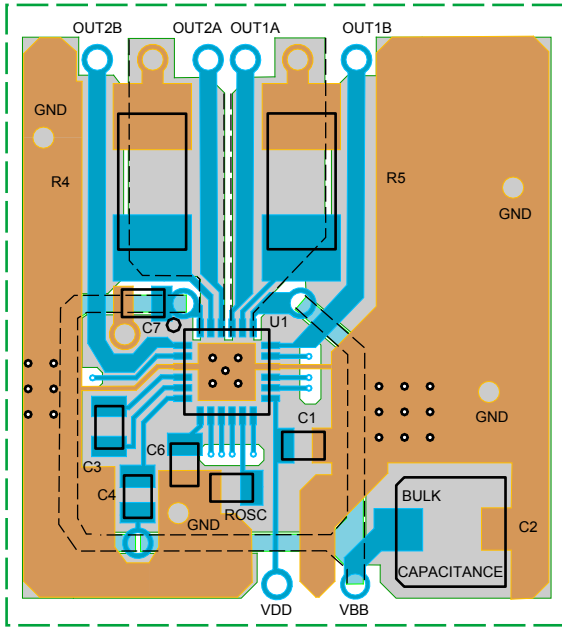

ES package configuration

PIN CIRCUIT DIAGRAMS

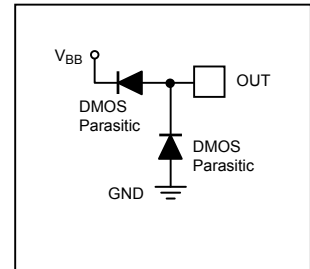
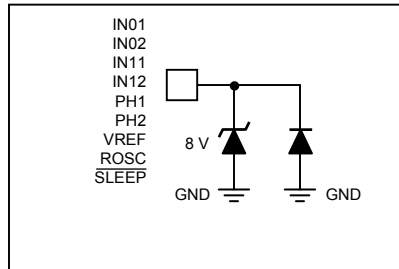
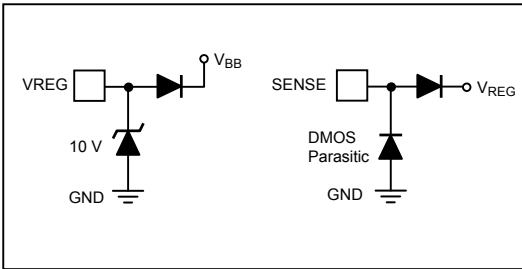
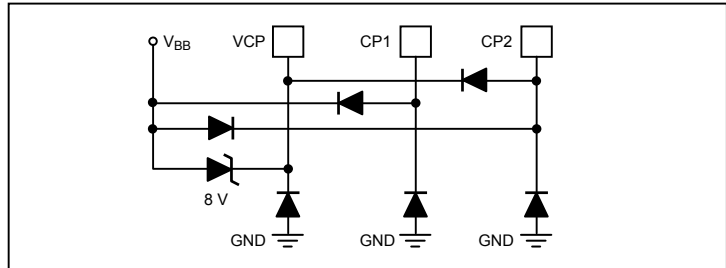
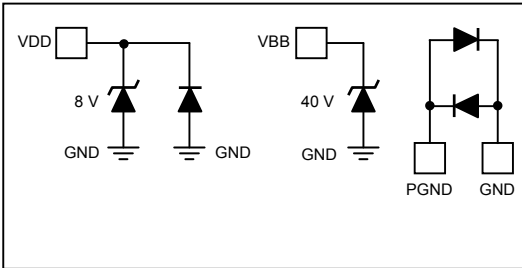

STEP SEQUENCING DIAGRAMS

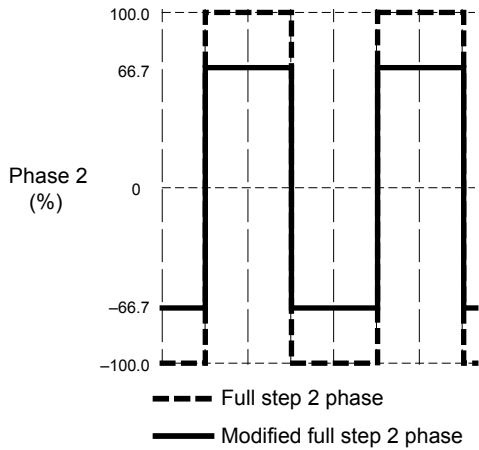
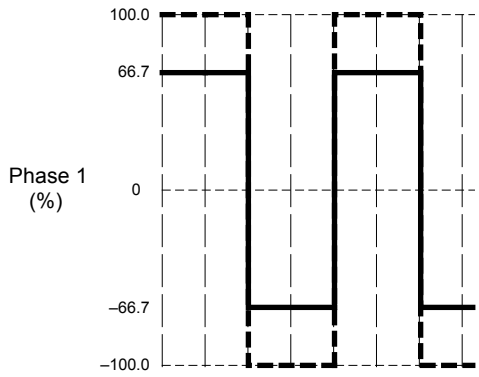

Figure 5. Step Sequencing for Full-Step Increments.

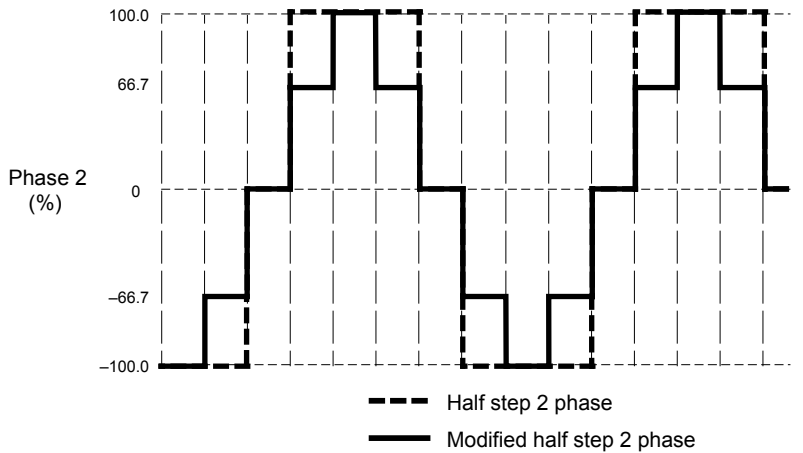
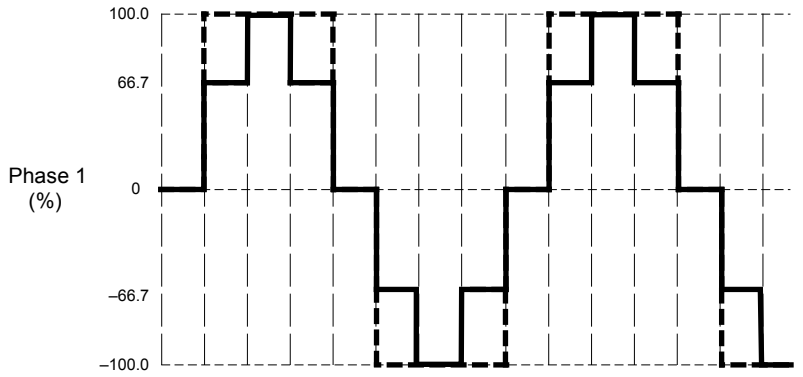

Figure 6. Step Sequencing for Half-Step Increments.

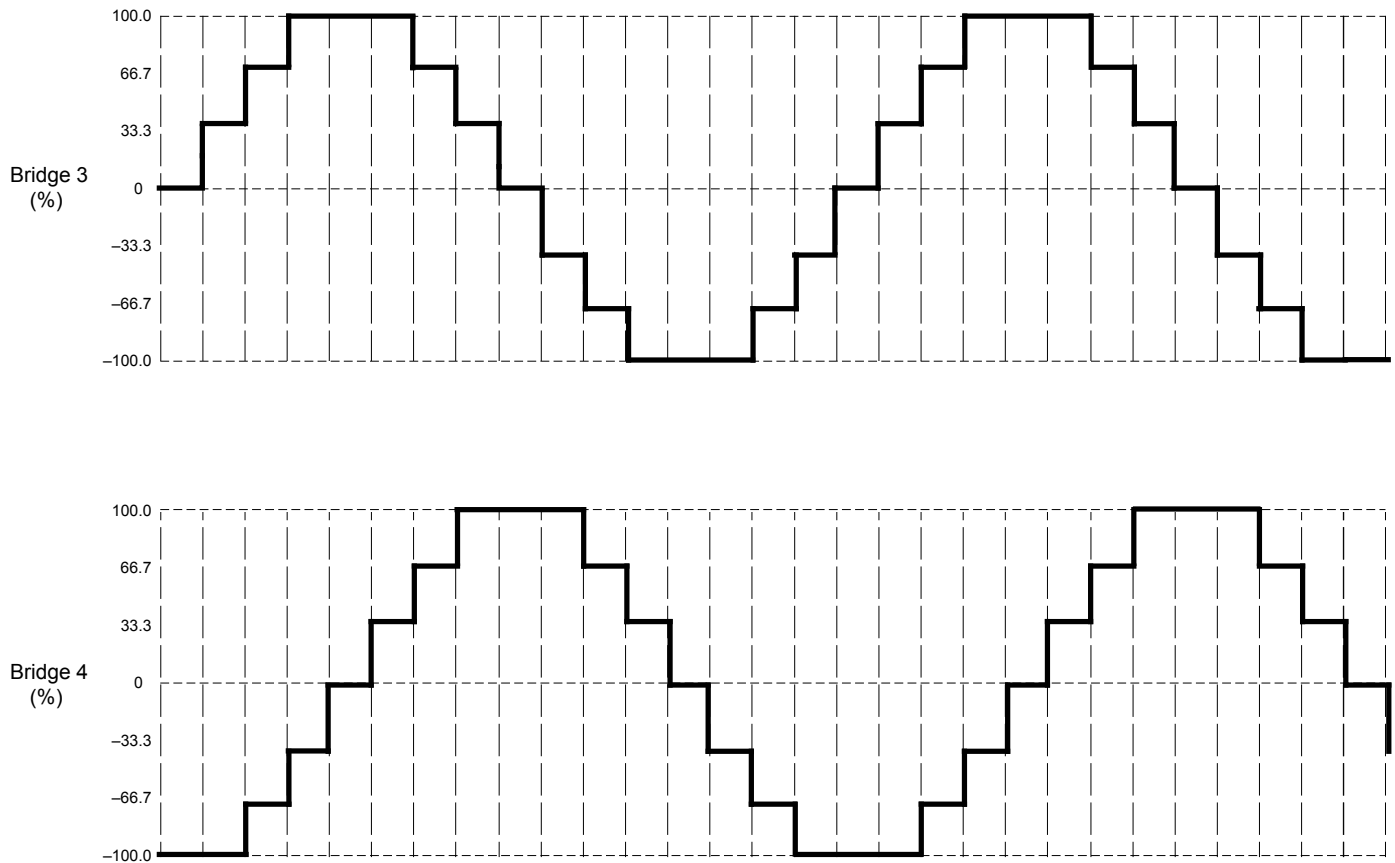

Figure 7. Step Sequence for Quarter-Step Increments

### Step Sequencing Settings

| Full | 1/2 | 1/4 | Phase 1<br>(%I <sub>TripMax</sub> ) | I01  | I11 | PHASE | Phase 2<br>(%I <sub>TripMax</sub> ) | I02  | I12 | PHASE |
|------|-----|-----|-------------------------------------|------|-----|-------|-------------------------------------|------|-----|-------|
|      | 1   | 1   | 0                                   | H    | H   | x     | 100                                 | L    | L   | 1     |
|      |     | 2   | 33                                  | L    | H   | 1     | 100                                 | L    | L   | 1     |
| 1    | 2   | 3   | 100/66*                             | L/H* | L   | 1     | 100/66*                             | L/H* | L   | 1     |
|      |     | 4   | 100                                 | L    | L   | 1     | 33                                  | L    | H   | 1     |
|      | 3   | 5   | 100                                 | L    | L   | 1     | 0                                   | H    | H   | X     |
|      |     | 6   | 100                                 | L    | L   | 1     | 33                                  | L    | H   | 0     |
| 2    | 4   | 7   | 100/66*                             | L/H* | L   | 1     | 100/66*                             | L/H* | L   | 0     |
|      |     | 8   | 33                                  | L    | H   | 1     | 100                                 | L    | L   | 0     |
|      | 5   | 9   | 0                                   | H    | H   | x     | 100                                 | L    | L   | 0     |
|      |     | 10  | 33                                  | L    | H   | 0     | 100                                 | L    | L   | 0     |
| 3    | 6   | 11  | 100/66*                             | L/H* | L   | 0     | 100/66*                             | L/H* | L   | 0     |
|      |     | 12  | 100                                 | L    | L   | 0     | 33                                  | L    | H   | 0     |
|      | 7   | 13  | 100                                 | L    | L   | 0     | 0                                   | H    | H   | X     |
|      |     | 14  | 100                                 | L    | L   | 0     | 33                                  | L    | H   | 1     |
| 4    | 8   | 15  | 100/66*                             | L/H* | L   | 0     | 100/66*                             | L/H* | L   | 1     |
|      |     | 16  | 33                                  | L    | H   | 0     | 100                                 | L    | L   | 1     |

\* Denotes modified step mode

## Pinout Diagrams

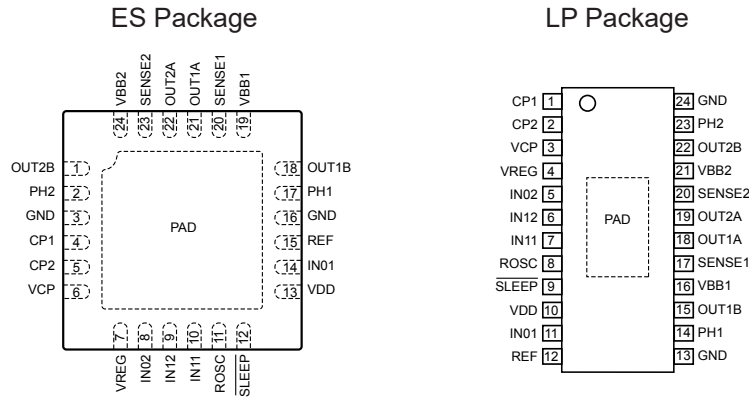

**Terminal List Table**

| Name   | Number |        | Description                                   |
|--------|--------|--------|-----------------------------------------------|
|        | ES     | LP     |                                               |
| CP1    | 4      | 1      | Charge pump capacitor terminal                |
| CP2    | 5      | 2      | Charge pump capacitor terminal                |
| PH1    | 17     | 14     | Logic input                                   |
| PH2    | 2      | 23     | Logic input                                   |
| GND    | 3, 16  | 13, 24 | Ground*                                       |
| IN02   | 8      | 5      | Logic input                                   |
| IN12   | 9      | 6      | Logic input                                   |
| OUT1A  | 21     | 18     | DMOS Full Bridge 1 Output A                   |
| OUT1B  | 18     | 15     | DMOS Full Bridge 1 Output B                   |
| OUT2A  | 22     | 19     | DMOS Full Bridge 2 Output A                   |
| OUT2B  | 1      | 22     | DMOS Full Bridge 2 Output B                   |
| REF    | 15     | 12     | G <sub>m</sub> reference voltage input        |
| IN11   | 10     | 7      | Logic input                                   |
| ROSC   | 11     | 8      | Timing set                                    |
| SENSE1 | 20     | 17     | Sense resistor terminal for Bridge 1          |
| SENSE2 | 23     | 20     | Sense resistor terminal for Bridge 2          |
| SLEEP  | 12     | 9      | Logic input                                   |
| IN01   | 14     | 11     | Logic input                                   |
| VBB1   | 19     | 16     | Load supply                                   |
| VBB2   | 24     | 21     | Load supply                                   |
| VCP    | 6      | 3      | Reservoir capacitor terminal                  |
| VDD    | 13     | 10     | Logic supply                                  |
| VREG   | 7      | 4      | Regulator decoupling terminal                 |
| PAD    | –      | –      | Exposed pad for enhanced thermal dissipation* |

\*The GND pins must be tied together externally by connecting to the PAD ground plane under the device.

## ES Package, 24-Pin QFN with Exposed Thermal Pad

### For Reference Only – Not for Tooling Use

(Reference Allegro DWG-0000222 Rev. 4 or JEDEC MO-220WGGD.)

Dimensions in millimeters – NOT TO SCALE.

Exact case and lead configuration at supplier discretion within limits shown.

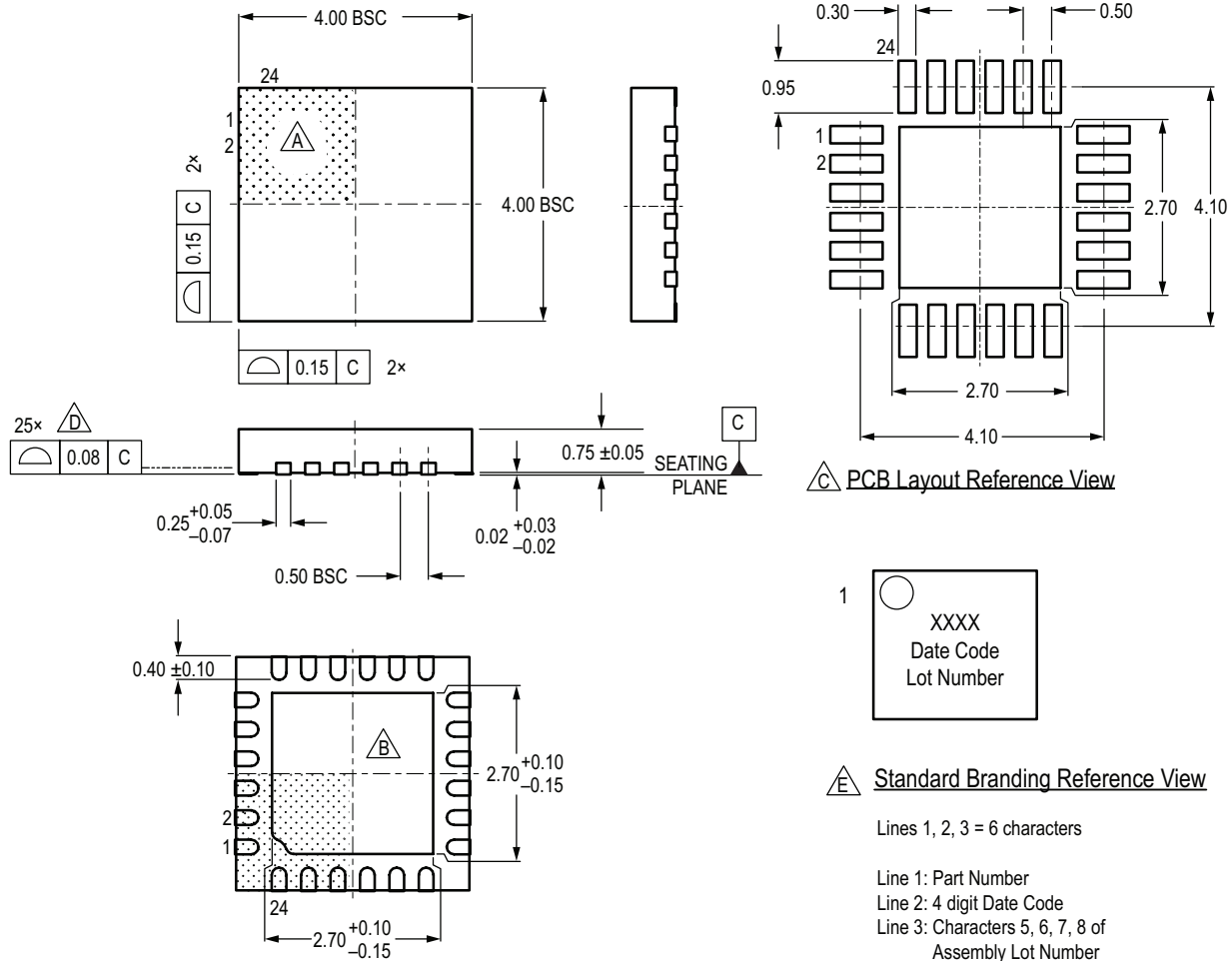

- A** Terminal #1 mark area
- B** Exposed thermal pad (reference only, terminal #1 identifier appearance at supplier discretion).
- C** Reference land pattern layout (reference IPC7351 QFN50P400X400X80-25W6M); all pads a minimum of 0.20 mm from all adjacent pads; adjust as necessary to meet application process requirements and PCB layout tolerances; when mounting on a multilayer PCB, thermal vias at the exposed thermal pad land can improve thermal dissipation (reference EIA/JEDEC Standard JESD51-5)
- D** Coplanarity includes exposed thermal pad and terminals
- E** Branding scale and appearance at supplier discretion.

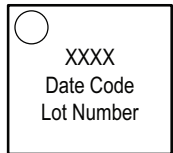

### **E** Standard Branding Reference View

Lines 1, 2, 3 = 6 characters

Line 1: Part Number  
Line 2: 4 digit Date Code  
Line 3: Characters 5, 6, 7, 8 of  
Assembly Lot Number

Pin 1 Dot top left  
Center align

## LP Package, 24-Pin TSSOP with Exposed Thermal Pad

### For Reference Only – Not for Tooling Use

(Reference Allegro DWG-0000379, Rev. 3 and JEDEC MO-153ADT)

NOT TO SCALE

Dimensions in millimeters

Dimensions exclusive of mold flash, gate burrs, and dambar protrusions  
Exact case and lead configuration at supplier discretion within limits shown

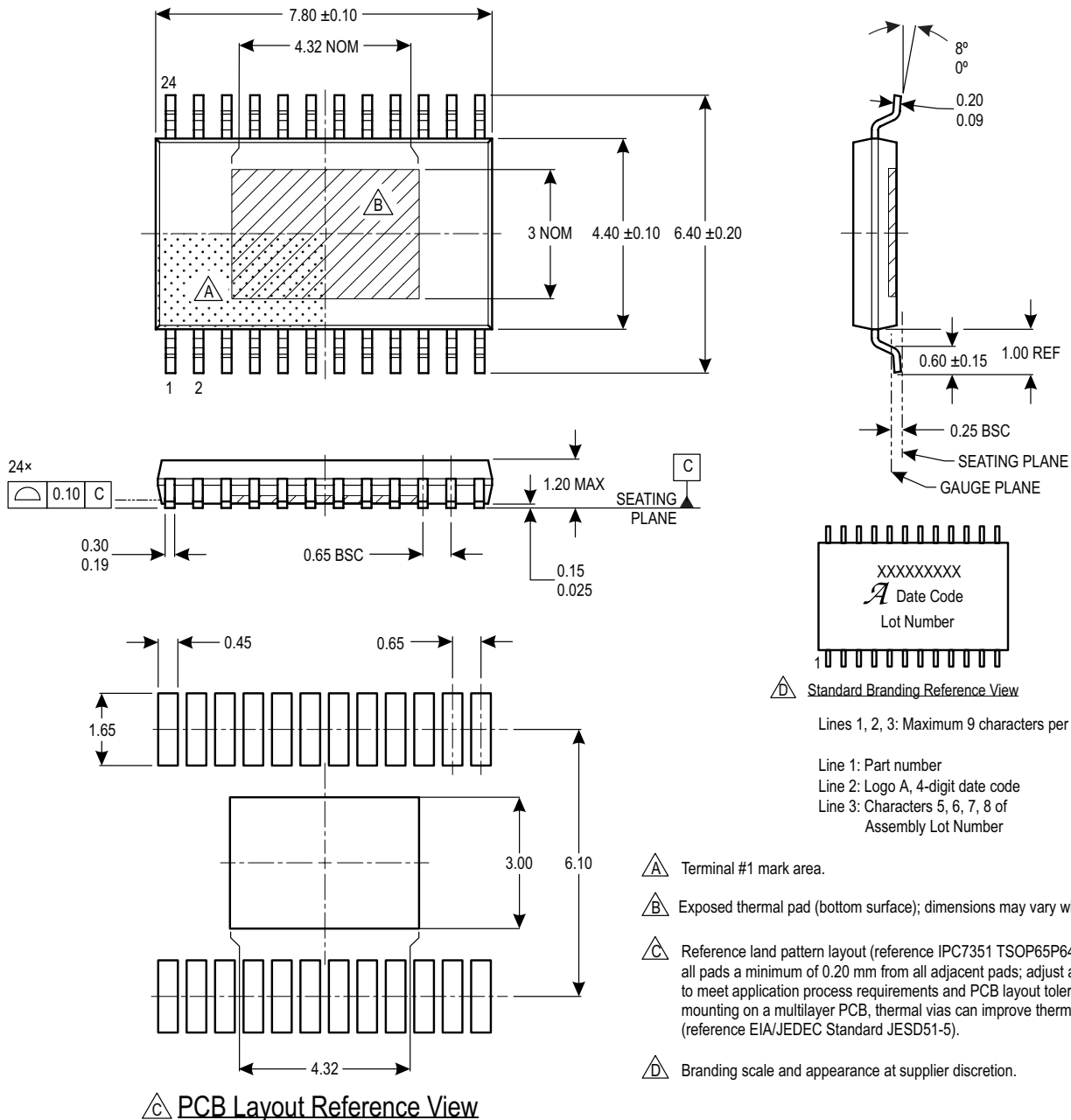



**Revision History**

| Number | Date           | Description                                                        |
|--------|----------------|--------------------------------------------------------------------|
| 4      | March 21, 2012 | Update Step Sequence and example layout                            |
| 5      | April 3, 2020  | Minor editorial updates                                            |
| 6      | March 25, 2022 | Updated package drawings (pages 15-16) and minor editorial updates |

Copyright 2022, Allegro MicroSystems.

Allegro MicroSystems reserves the right to make, from time to time, such departures from the detail specifications as may be required to permit improvements in the performance, reliability, or manufacturability of its products. Before placing an order, the user is cautioned to verify that the information being relied upon is current.

Allegro's products are not to be used in any devices or systems, including but not limited to life support devices or systems, in which a failure of Allegro's product can reasonably be expected to cause bodily harm.

The information included herein is believed to be accurate and reliable. However, Allegro MicroSystems assumes no responsibility for its use; nor for any infringement of patents or other rights of third parties which may result from its use.

Copies of this document are considered uncontrolled documents.

For the latest version of this document, visit our website:

[www.allegromicro.com](http://www.allegromicro.com)