

Quad DMOS Full Bridge PWM Motor Driver

FEATURES AND BENEFITS

- 36 V output rating
- 4 full bridges
- Dual stepper motor driver
- High current outputs
- 3.3 and 5 V compatible logic supply
- Synchronous rectification
- Internal undervoltage lockout (UVLO)
- Thermal shutdown circuitry
- Crossover-current protection
- Low profile QFN package

PACKAGES

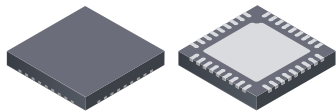

Package EV, 36-pin QFN
0.90 mm nominal height
with exposed thermal pad

*Approximate
footprint*

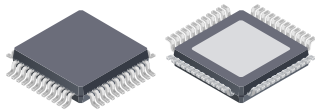

Package JP, 48-pin LQFP
with exposed thermal pad

DESCRIPTION

The A3988 is a quad DMOS full-bridge driver capable of driving up to two stepper motors or four DC motors. Each full-bridge output is rated up to 1.2 A and 36 V. The A3988 includes fixed off-time pulse width modulation (PWM) current regulators, along with 2-bit nonlinear DACs (digital-to-analog converters) that allow stepper motors to be controlled in full, half, and quarter steps, and DC motors in forward, reverse, and coast modes. The PWM current regulator uses the Allegro™ patented mixed decay mode for reduced audible motor noise, increased step accuracy, and reduced power dissipation.

Internal synchronous rectification control circuitry is provided to improve power dissipation during PWM operation.

Protection features include thermal shutdown with hysteresis, undervoltage lockout (UVLO) and crossover current protection. Special power up sequencing is not required.

The A3988 is supplied in two packages, EV and JP, with exposed power tabs for enhanced thermal performance. The EV is a 6 mm × 6 mm, 36-pin QFN package with a nominal overall package height of 0.90 mm. The JP is a 7 mm × 7 mm 48-pin LQFP. Both packages are lead (Pb) free, with 100% matte tin leadframe plating.

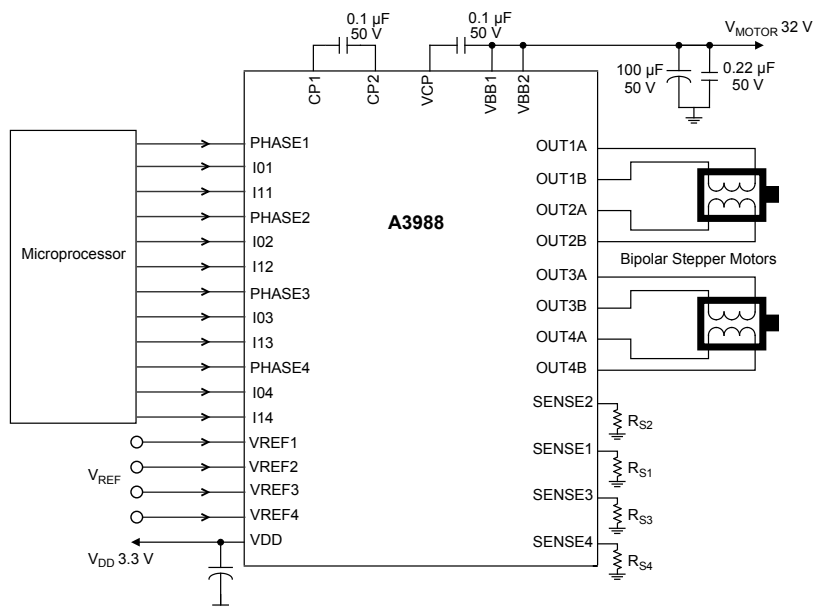

Typical Application Circuit

SPECIFICATIONS

SELECTION GUIDE

Part Number	Package	Packing	Fixed off-time (μs)
A3988SEV-T	36-pin QFN with exposed thermal pad	61 pieces per tube	30
A3988SEVTR-T	36-pin QFN with exposed thermal pad	1500 pieces per reel	30
A3988SJPTR-T	48-pin LQFP with exposed thermal pad	1500 pieces per reel	30
A3988SEVTR-1-T ^[1]	36-pin QFN with exposed thermal pad	1500 pieces per reel	8.1
A3988SJPTR-1-T ^[1]	48-pin LQFP with exposed thermal pad	1500 pieces per reel	8.1

^[1] Part variants A3988SEVTR-1-T and A3988SJPTR-1-T are no longer in production. These devices should not be purchased for new design applications. Samples are no longer available. Status change date: September 30, 2024 Suggested replacements: A5988GEVTR-1-T(A3988SEVTR-1-T), A5988GJPTR-1-T (A3988SJPTR-1-T).

ABSOLUTE MAXIMUM RATINGS

Characteristic	Symbol	Notes	Rating	Units
Load Supply Voltage	V_{BB}		-0.5 to 36	V
		Pulsed $t_w < 1 \mu\text{s}$	38	V
Logic Supply Voltage	V_{DD}		-0.4 to 7	V
Output Current	I_{OUT}	May be limited by duty cycle, ambient temperature, and heat sinking. Under any set of conditions, do not exceed the specified current rating or a Junction Temperature of 150°C.	1.2	A
		Pulsed $t_w < 1 \mu\text{s}$	2.8	A
Logic Input Voltage Range	V_{IN}		-0.3 to 7	V
SENSE _x Pin Voltage	V_{SENSE_x}		0.5	V
		Pulsed $t_w < 1 \mu\text{s}$	2.5	V
VREF _x Pin Voltage	V_{REF_x}		2.5	V
Operating Temperature Range	T_{A}	Range S	-20 to 85	°C
Junction Temperature	$T_{\text{J}}(\text{max})$		150	°C
Storage Temperature Range	T_{stg}		-40 to 125	°C

THERMAL CHARACTERISTICS (may require derating at maximum conditions)

Characteristic	Symbol	Test Conditions	Min.	Units
Package Thermal Resistance	$R_{\theta JA}$	EV package, 4-layer PCB based on JEDEC standard	27	°C/W
		JP package, 4-layer PCB based on JEDEC standard	23	°C/W

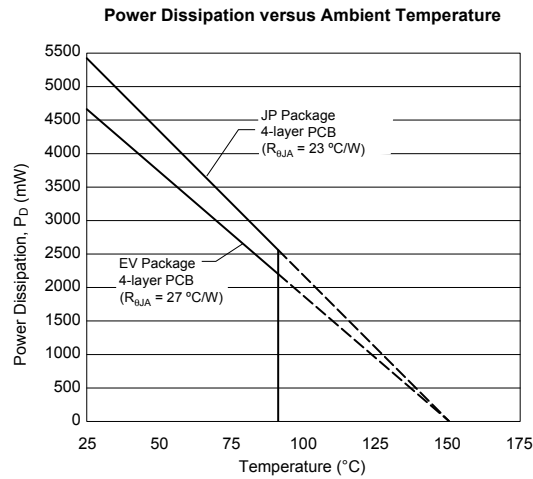

FUNCTIONAL BLOCK DIAGRAM

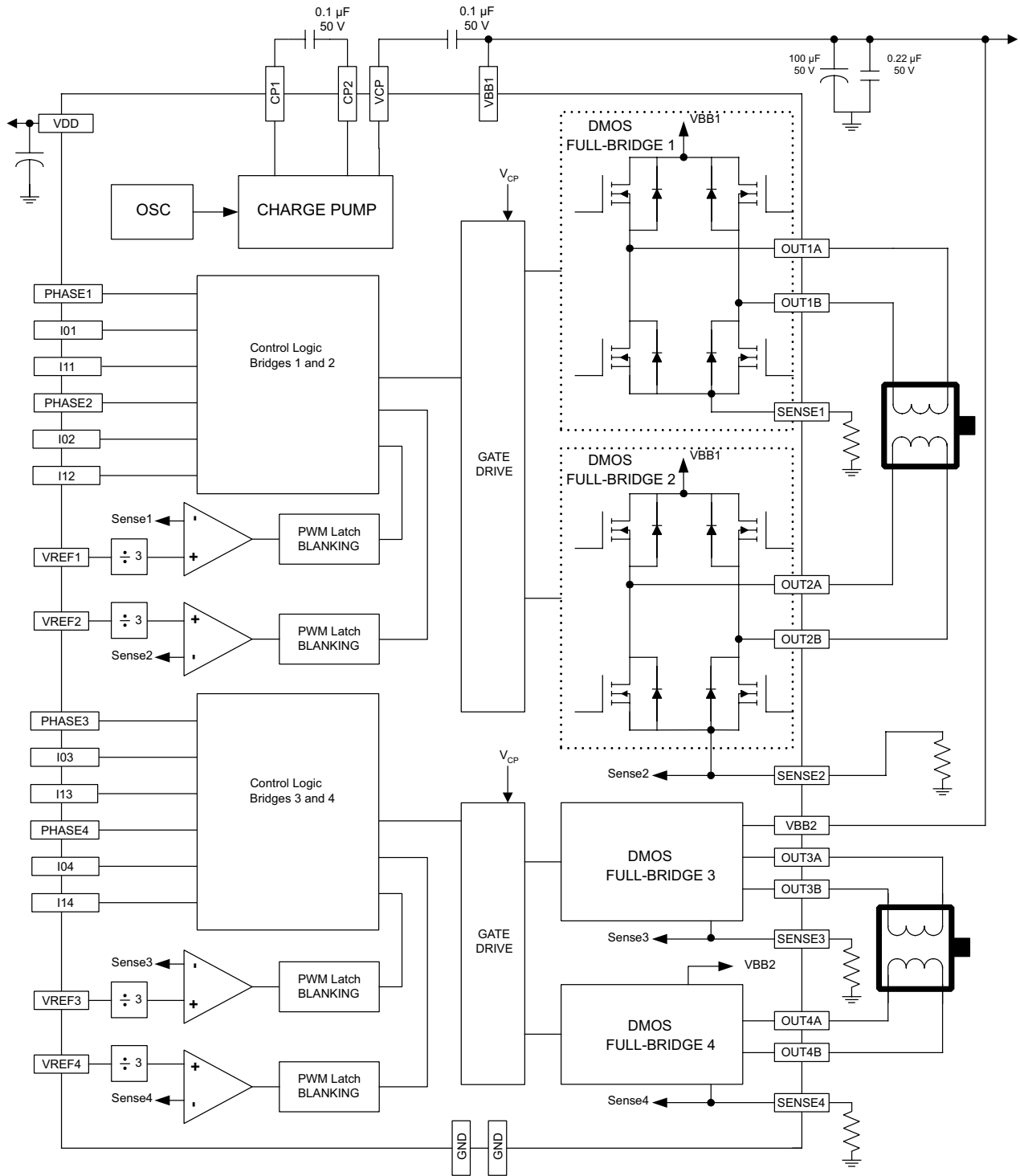

PINOUT DIAGRAMS AND TERMINAL LIST TABLE

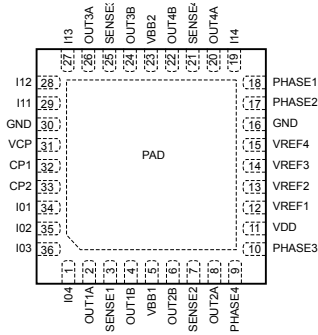

Package EV, 36-Pin QFN Pinout

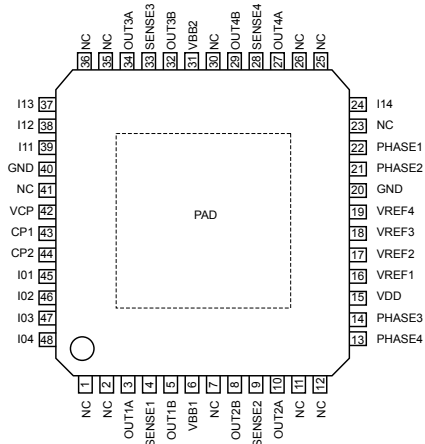

Package JP, 48-Pin LQFP Pinout

Terminal List Table

Number		Pin Name	Pin Description
EV	JP		
2	3	OUT1A	DMOS Full-Bridge 1 Output A
3	4	SENSE1	Sense Resistor Terminal for Bridge 1
4	5	OUT1B	DMOS Full-Bridge 1 Output B
5	6	VBB1	Load Supply Voltage
6	8	OUT2B	DMOS Full-Bridge 2 Output B
7	9	SENSE2	Sense Resistor Terminal for Bridge 2
8	10	OUT2A	DMOS Full-Bridge 2 Output A
9	13	PHASE4	Control Input
10	14	PHASE3	Control Input
11	15	VDD	Logic Supply Voltage
12	16	VREF1	Analog Input
13	17	VREF2	Analog Input
14	18	VREF3	Analog Input
15	19	VREF4	Analog Input
16	20	GND	Ground
17	21	PHASE2	Control Input
18	22	PHASE1	Control Input
19	24	I14	Control Input
20	27	OUT4A	DMOS Full-Bridge 4 Output A
21	28	SENSE4	Sense Resistor Terminal for Bridge 4
22	29	OUT4B	DMOS Full-Bridge 4 Output B
23	31	VBB2 ¹	Load Supply Voltage
24	32	OUT3B	DMOS Full-Bridge 3 Output B
25	33	SENSE3	Sense Resistor Terminal for Bridge 3
26	34	OUT3A	DMOS Full-Bridge 3 Output A
27	37	I13	Control Input
28	38	I12	Control Input
29	39	I11	Control Input
30	40	GND	Ground
31	42	VCP	Reservoir Capacitor Terminal
32	43	CP1	Charge Pump Capacitor Terminal
33	44	CP2	Charge Pump Capacitor Terminal
34	45	I01	Control Input
35	46	I02	Control Input
36	47	I03	Control Input
1	48	I04	Control Input
-	1, 2, 7, 11, 12, 23, 25, 26, 30, 35, 36, 41	NC	No Connect
-	-	PAD	Exposed pad for enhanced thermal performance. Should be soldered to the PCB.

^[1] VBB1 and VBB2 need to be connected together close to the A3988.

ELECTRICAL CHARACTERISTICS [1]: Valid at $T_A = 25^\circ\text{C}$, $V_{BB} = 36\text{ V}$, unless otherwise noted

Characteristics	Symbol	Test Conditions	Min.	Typ. [2]	Max.	Units
Load Supply Voltage Range	V_{BB}	Operating	8.0	–	36	V
Logic Supply Voltage Range	V_{DD}	Operating	3.0	–	5.5	V
VDD Supply Current	I_{DD}		–	7	10	mA
Output On Resistance	$R_{DS(on)}$	Source driver, $I_{OUT} = -1.2\text{ A}$, $T_J = 25^\circ\text{C}$	–	700	800	m Ω
		Sink driver, $I_{OUT} = 1.2\text{ A}$, $T_J = 25^\circ\text{C}$	–	700	800	m Ω
V_f , Outputs		$I_{OUT} = 1.2\text{ A}$	–	–	1.3	V
Output Leakage	I_{DSS}	Outputs, $V_{OUT} = 0$ to V_{BB}	–20	–	20	μA
VBB Supply Current	I_{BB}	$I_{OUT} = 0\text{ mA}$, outputs on, PWM = 50 kHz, DC = 50%	–	–	8	mA
CONTROL LOGIC						
Logic Input Voltage	$V_{IN(1)}$		$0.7 \times V_{DD}$	–	–	V
	$V_{IN(0)}$		–	–	$0.3 \times V_{DD}$	V
Logic Input Current	I_{IN}	$V_{IN} = 0$ to 5 V	–20	<1.0	20	μA
Input Hysteresis	V_{hys}		150	300	500	mV
Propagation Delay Times	t_{pd}	PWM change to source on	350	550	1000	ns
		PWM change to source off	35	–	300	ns
		PWM change to sink on	350	550	1000	ns
		PWM change to sink off	35	–	250	ns
Crossover Delay	t_{COD}		300	425	1000	ns
Blank Time	t_{BLANK}		0.7	1	1.3	μs
VREFx Pin Input Voltage Range	V_{REFx}	Operating	0.0	–	1.5	V
VREFx Pin Reference Input Current	I_{REF}	$V_{REF} = 1.5$	–	–	± 1	μA
Current Trip-Level Error [3]	V_{ERR}	$V_{REF} = 1.5$, phase current = 100%	–5	–	5	%
		$V_{REF} = 1.5$, phase current = 67%	–5	–	5	%
		$V_{REF} = 1.5$, phase current = 33%	–15	–	15	%
PROTECTION CIRCUITS						
VBB UVLO Threshold	$V_{UV(VBB)}$	V_{BB} rising	7.3	7.6	7.9	V
VBB Hysteresis	$V_{UV(VBB)hys}$		400	500	600	mV
VDD UVLO Threshold	$V_{UV(VDD)}$	V_{DD} rising	2.65	2.8	2.95	V
VDD Hysteresis	$V_{UV(VDD)hys}$		75	105	125	mV
Thermal Shutdown Temperature	T_{JTSD}		155	165	175	$^\circ\text{C}$
Thermal Shutdown Hysteresis	$T_{JTSDhys}$		–	15	–	$^\circ\text{C}$

[1] For input and output current specifications, negative current is defined as coming out of (sourcing) the specified device pin.

[2] Typical data are for initial design estimations only, and assume optimum manufacturing and application conditions. Performance may vary for individual units, within the specified maximum and minimum limits.

[3] $V_{ERR} = [(V_{REF}/3) - V_{SENSE}] / (V_{REF}/3)$.

FUNCTIONAL DESCRIPTION

Device Operation

The A3988 is designed to operate two stepper motors, four DC motors, or one stepper and two DC motors. The currents in each of the output full-bridges, all N-channel DMOS, are regulated with fixed off-time pulse width modulated (PWM) control circuitry. Each full-bridge peak current is set by the value of an external current sense resistor, R_{Sx} , and a reference voltage, V_{REFx} .

If the logic inputs are pulled up to V_{DD} , it is good practice to use a high value pull-up resistor in order to limit current to the logic inputs, should an overvoltage event occur. Logic inputs include: PHASE_x, I0_x, and I1_x.

Internal PWM Current Control

Each full-bridge is controlled by a fixed off-time PWM current control circuit that limits the load current to a desired value, I_{TRIP} . Initially, a diagonal pair of source and sink DMOS outputs are enabled and current flows through the motor winding and R_{Sx} . When the voltage across the current sense resistor equals the voltage on the VREF_x pin, the current sense comparator resets the PWM latch, which turns off the source driver.

The maximum value of current limiting is set by the selection of R_S and the voltage at the VREF input with a transconductance function approximated by:

$$I_{TripMax} = V_{REF} / (3 \times R_S)$$

Each current step is a percentage of the maximum current, $I_{TripMax}$. The actual current at each step I_{Trip} is approximated by:

$$I_{Trip} = (\% I_{TripMax} / 100) I_{TripMax}$$

where % $I_{TripMax}$ is given in the Step Sequencing table.

Note: It is critical to ensure that the maximum rating of ± 500 mV on each SENSE_x pin is not exceeded.

Fixed Off-Time

The internal PWM current control circuitry uses a one-shot circuit to control the time the drivers remain off. For the A3988 variant, the off-time (t_{off}) is 30 μ s. For the A3988-1 variant, t_{off} is 8.1 μ s.

Blanking

This function blanks the output of the current sense comparator when the outputs are switched by the internal current control circuitry. The comparator output is blanked to prevent false detections of overcurrent conditions, due to reverse recovery currents of the clamp diodes, or to switching transients related to the capacitance of the load. The stepper blank time, t_{BLANK} , is approximately 1 μ s.

Control Logic

Communication is implemented via the industry standard I1, I0, and PHASE interface. This communication logic allows for full, half, and quarter step modes. Each bridge also has an independent V_{REF} input so higher resolution step modes can be programmed by dynamically changing the voltage on the VREF_x pins.

Charge Pump (CP1 and CP2)

The charge pump is used to generate a gate supply greater than the V_{BB} in order to drive the source-side DMOS gates. A 0.1 μ F ceramic capacitor should be connected between CP1 and CP2 for pumping purposes. A 0.1 μ F ceramic capacitor is required between VCP and VBB_x to act as a reservoir to operate the high-side DMOS devices.

Shutdown

In the event of a fault (excessive junction temperature, or low voltage on VCP), the outputs of the device are disabled until the fault condition is removed. At power-up, the undervoltage lock-out (UVLO) circuit disables the drivers.

Synchronous Rectification

When a PWM-off cycle is triggered by an internal fixed off-time cycle, load current will recirculate. The A3988 synchronous rectification feature will turn on the appropriate MOSFETs during the current decay, and effectively short out the body diodes with the low $R_{DS(on)}$ driver. This significantly lowers power dissipation. When a zero current level is detected, synchronous rectification is turned off to prevent reversal of the load current.

Mixed Decay Operation

The bridges operate in mixed decay mode. Referring to Figure 1, as the trip point is reached, the device goes into fast decay mode for 30.1% of the fixed off-time period. After this fast decay portion, t_{FD} , the device switches to slow decay mode for the remainder of the off-time. During transitions from fast decay to slow decay, the drivers are forced off for approximately 600 ns. This feature is added to prevent shoot-through in the bridge. As shown in Figure 1, during this “dead time” portion, synchronous rectification is not active, and the device operates in fast decay and slow decay only.

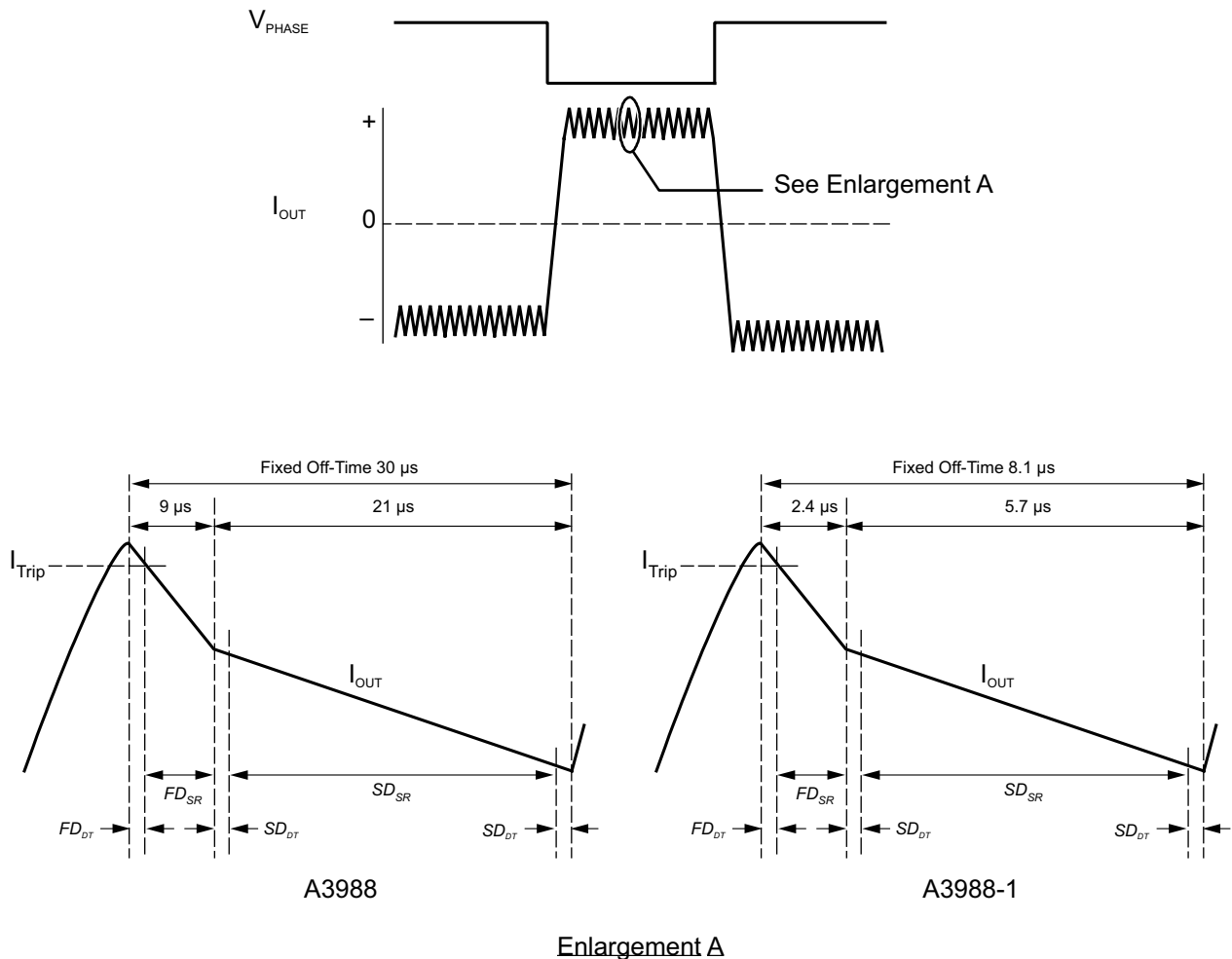

Figure 1: Mixed Decay Mode Operation

STEP SEQUENCING DIAGRAMS

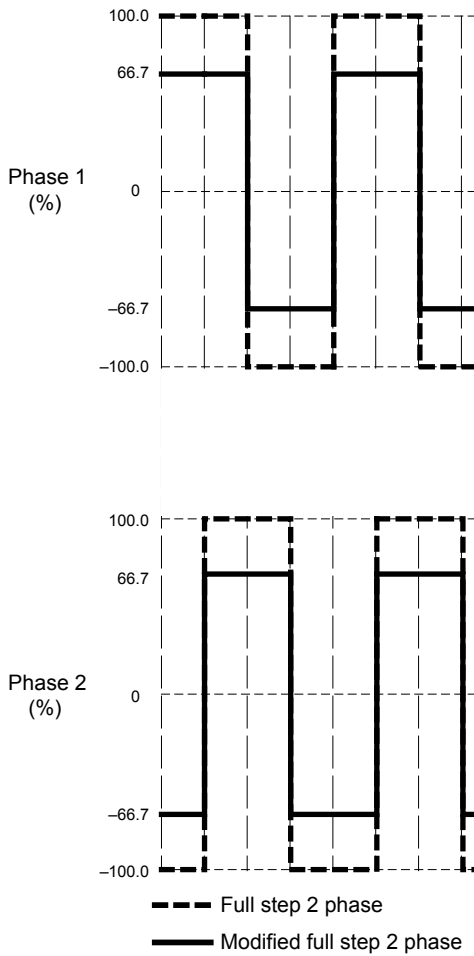

Figure 2: Step Sequencing for Full-Step Increments

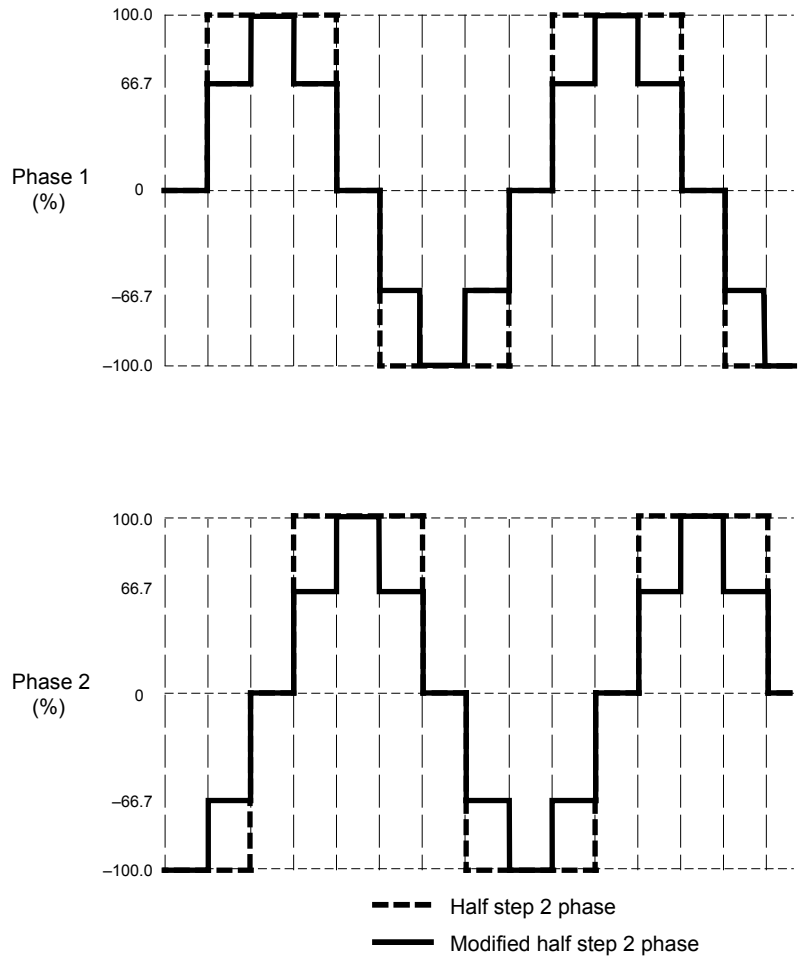

Figure 3: Step Sequencing for Half-Step Increments

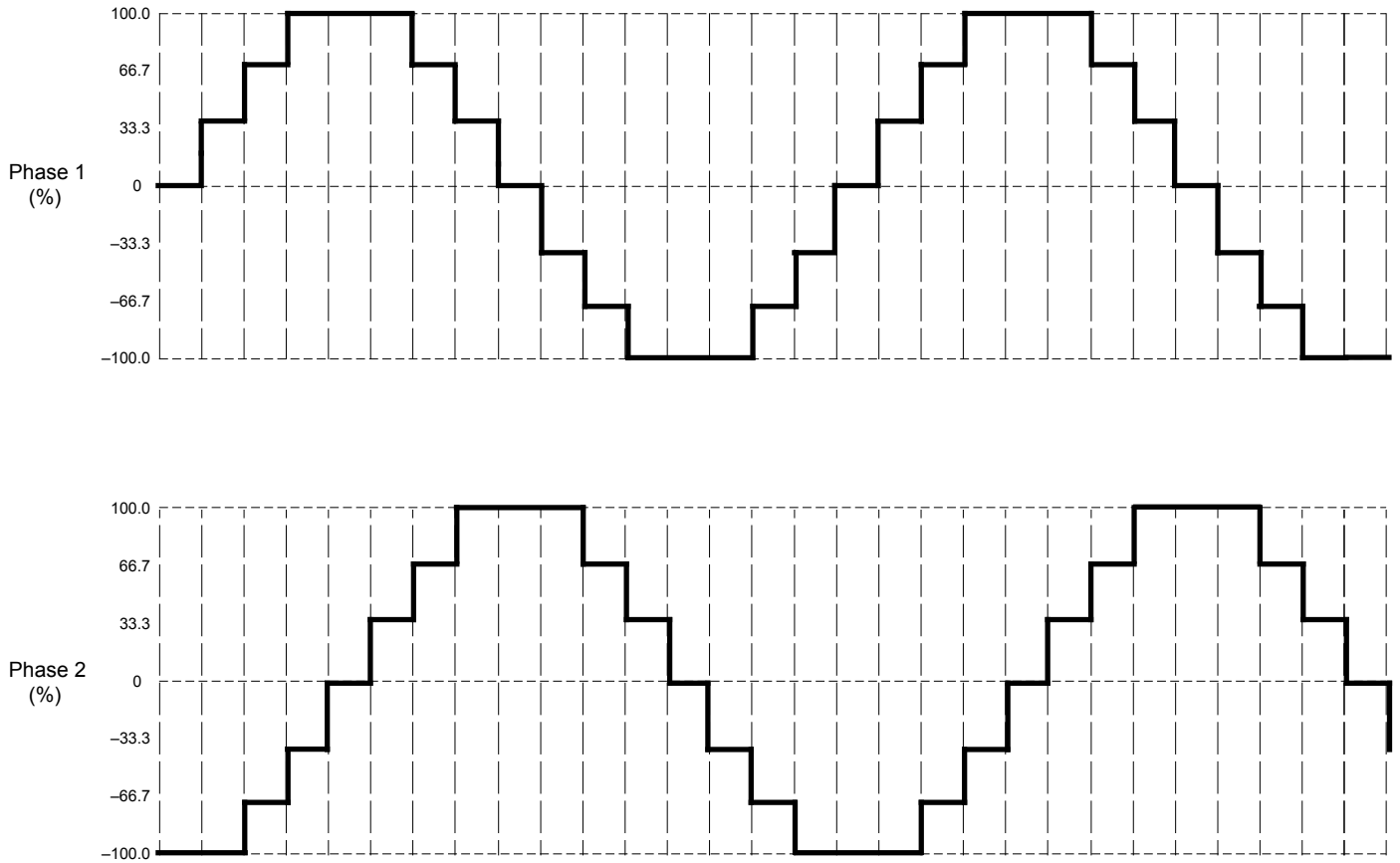

Figure 4: Step Sequence for Quarter-Step Increments

Table 1: Step Sequencing Settings

Full	1/2	1/4	Phase 1 (%I _{TripMax})	I0x	I1x	PHASE	Phase 2 (%I _{TripMax})	I0x	I1x	PHASE
	1	1	0	H	H	X	100	L	L	0
		2	33	L	H	1	100	L	L	0
1	2	3	100/66*	L/H*	L	1	100/66*	L/H*	L	0
		4	100	L	L	1	33	L	H	0
	3	5	100	L	L	1	0	H	H	X
		6	100	L	L	1	33	L	H	1
2	4	7	100/66*	L/H*	L	1	100/66*	L/H*	L	1
		8	33	L	H	1	100	L	L	1
	5	9	0	H	H	X	100	L	L	1
		10	33	L	H	0	100	L	L	1
3	6	11	100/66*	L/H*	L	0	100/66*	L/H*	L	1
		12	100	L	L	0	33	L	H	1
	7	13	100	L	L	0	0	H	H	X
		14	100	L	L	0	33	L	H	0
4	8	15	100/66*	L/H*	L	0	100/66*	L/H*	L	0
		16	33	L	H	0	100	L	L	0

*Denotes modified step mode

APPLICATIONS INFORMATION

Motor Configurations

For applications that require either a stepper/DC motor driver or dual DC motor driver, Allegro offers the A3989 and A3995. These devices are offered in the same 36-pin QFN package as the A3988. The DC motor drivers are capable of supplying 2.4 A at 36 V. Commutation is done with a standard phase/enable logic interface. Please refer to the Allegro website for further information and datasheets about those devices.

DC Motor Control

Each of the 4 full bridges has independent PWM current control circuitry that makes the A3988 capable of driving up to four DC motors at currents up to 1.2 A. Control of the DC motors is accomplished by tying the I0, I1 pins together creating an equivalent ENABLE function with maximum current defined by the voltage on the corresponding VREF pin. The DC motors can be driven via a PWM signal on this enable signal, or on the corresponding PHASE pin. Motor control includes forward, reverse, and coast.

Layout

The printed circuit board should use a heavy ground plane. For optimum electrical and thermal performance, the A3988 must be soldered directly onto the board. On the underside of the A3988 package is an exposed pad, which provides a path for enhanced thermal dissipation. The thermal pad should be soldered directly to an exposed surface on the PCB. Thermal vias are used to transfer heat to other layers of the PCB.

Grounding

In order to minimize the effects of ground bounce and offset issues, it is important to have a low impedance single-point ground, known as a *star ground*, located very close to the device. By making the connection between the exposed thermal pad and

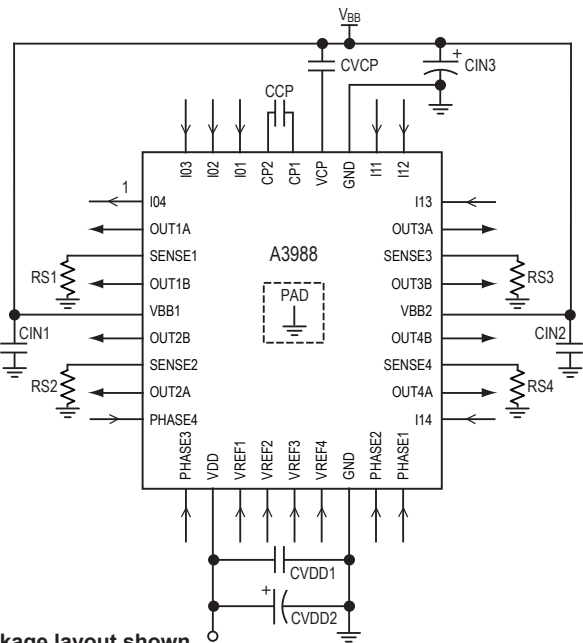
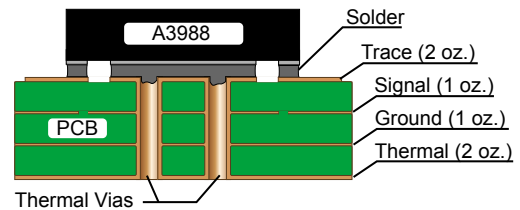
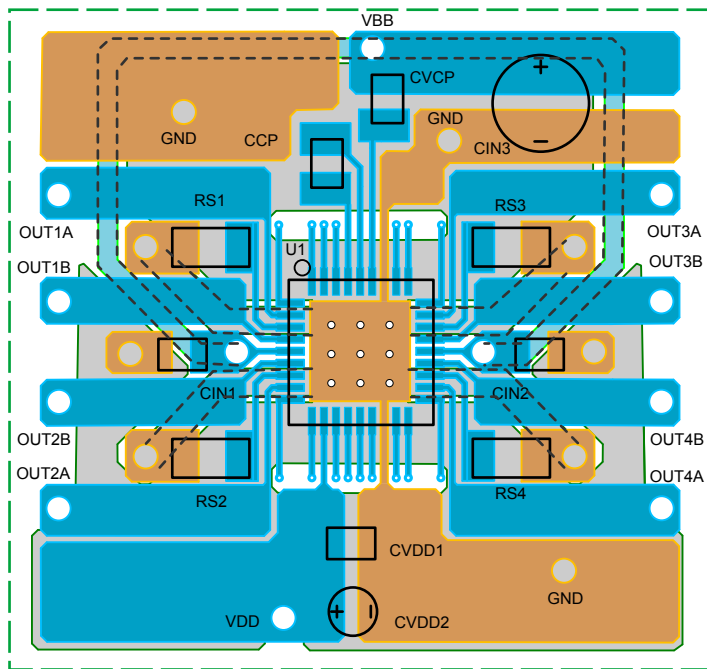

EV package layout shown

Figure 5: Printed circuit board layout with typical application circuit, shown at right.

The copper area directly under the A3988 (U1) is soldered to the exposed thermal pad on the underside of the device. The thermal vias serve also as electrical vias, connecting it to the ground plane on the other side of the PCB, so the two copper areas together form the star ground.

the ground plane directly under the A3988, that area becomes an ideal location for a star ground point.

A low impedance ground will prevent ground bounce during high current operation and ensure that the supply voltage remains stable at the input terminal. The recommended PCB layout shown in the diagram below, illustrates how to create a star ground under the device, to serve both as low impedance ground point and thermal path.

The two input capacitors should be placed in parallel, and as close to the device supply pins as possible. The ceramic capacitor should be closer to the pins than the bulk capacitor. This is necessary because the ceramic capacitor will be responsible for delivering the high frequency current components.

Sense Pins

The sense resistors, RS_x , should have a very low impedance path to ground, because they must carry a large current while supporting very accurate voltage measurements by the current sense comparators. Long ground traces will cause additional voltage drops, adversely affecting the ability of the comparators to accurately measure the current in the windings. As shown in the layout below, the $SENSE_x$ pins have very short traces to the RS_x resistors and very thick, low impedance traces directly to the star ground underneath the device. If possible, there should be no other components on the sense circuits.

Note:

When selecting a value for the sense resistors, be sure not to exceed the maximum voltage on the $SENSE_x$ pins of ± 500 mV.

PACKAGE OUTLINE DRAWINGS

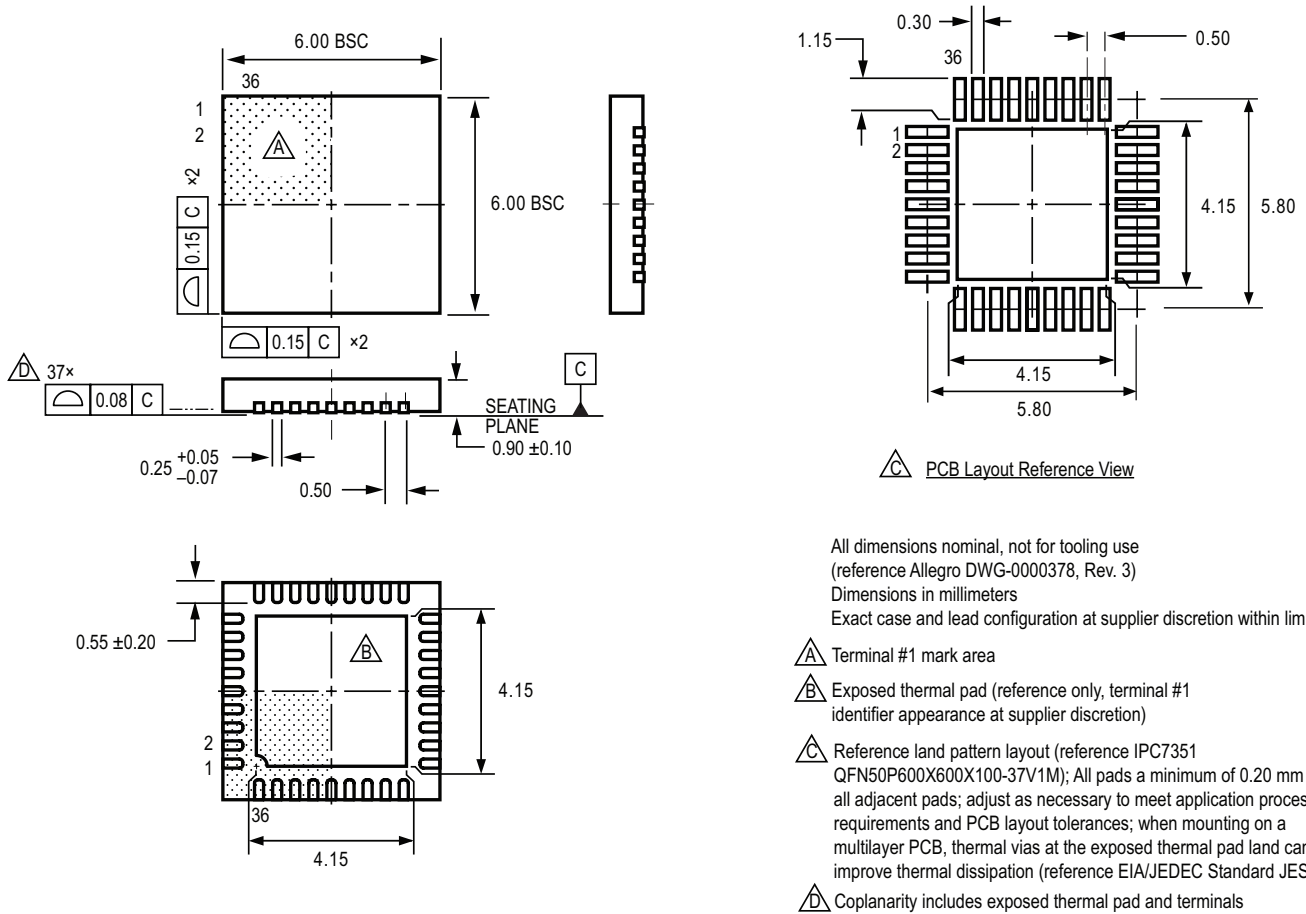

Figure 6: EV Package, 36-Pin QFN with Exposed Thermal Pad

For Reference Only – Not for Tooling Use

(Reference Allegro DWG-0000386, Rev. 5 or JEDEC MS-026 BBCHD)

NOT TO SCALE

Dimensions in millimeters

Dimensions exclusive of mold flash, gate burrs, and dambar protrusions
Exact case and lead configuration at supplier discretion within limits shown

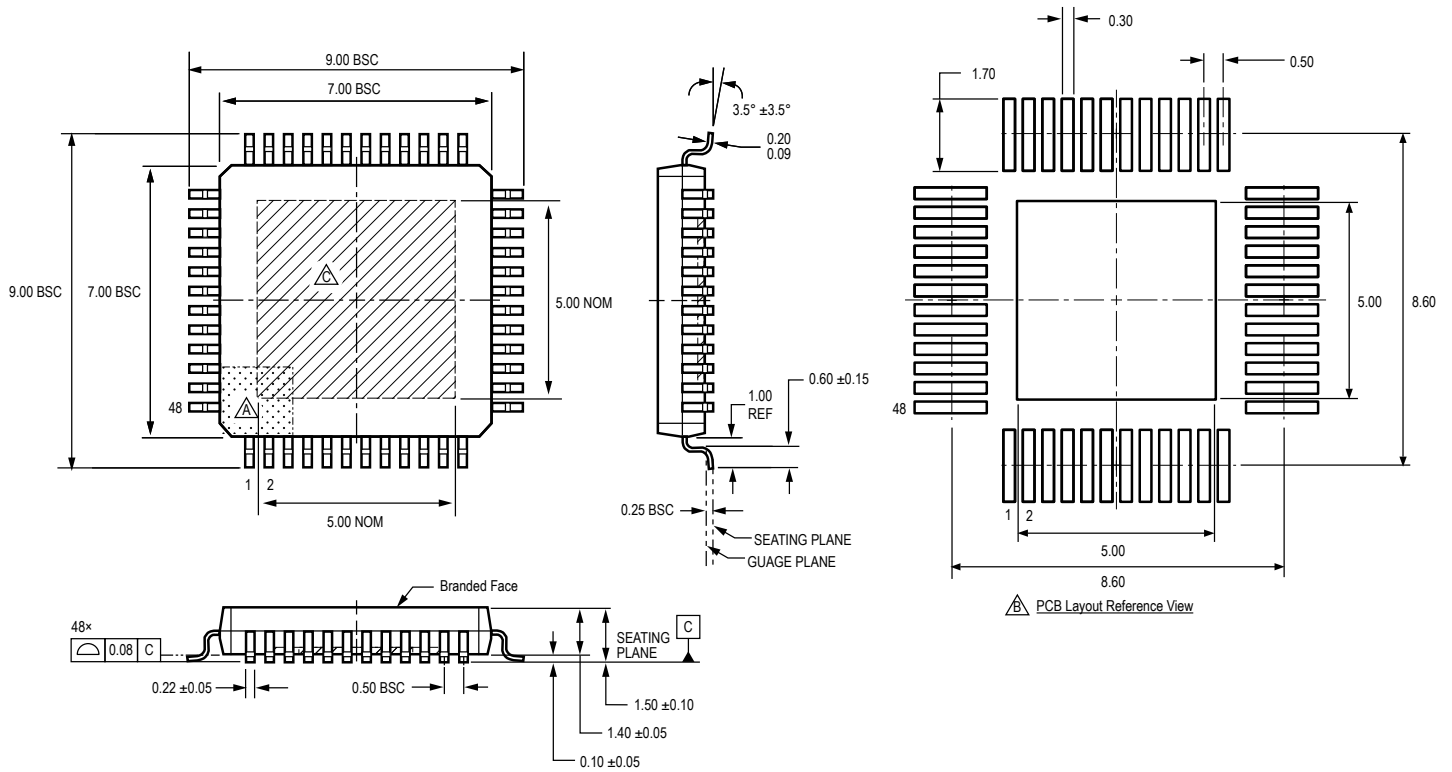

- △ Terminal #1 mark area
- △ Reference land pattern layout (reference IPC7351 QFP50P900X900X160-48M); adjust as necessary to meet application process requirements and PCB layout tolerances; when mounting on a multilayer PCB, thermal vias at the exposed thermal pad land can improve thermal dissipation (reference EIA/JEDEC Standard JESD51-5)
- △ Exposed thermal pad (bottom surface); exact dimensions may vary with device

Figure 7: JP Package, 48-Pin LQFP with Exposed Thermal Pad

Revision History

Number	Date	Description
9	June 14, 2011	Change in packing options
10	July 9, 2014	Revised Step Sequence Settings table and Functional Block Diagram
11	October 21, 2014	Added -1 variant
12	December 10, 2019	Minor editorial updates
13	December 13, 2021	Updated package drawings (pages 12-13) and other minor editorial updates
14	March 11, 2024	Part variants A3988SEVTR-1-T and A3988SJPTR-1-T status changed to Last-Time Buy (page 2).
15	September 13, 2024	Part variants A3988SEVTR-1-T and A3988SJPTR-1-T status changed to Discontinued (page 2).

Copyright 2024, Allegro MicroSystems.

Allegro MicroSystems reserves the right to make, from time to time, such departures from the detail specifications as may be required to permit improvements in the performance, reliability, or manufacturability of its products. Before placing an order, the user is cautioned to verify that the information being relied upon is current.

Allegro's products are not to be used in any devices or systems, including but not limited to life support devices or systems, in which a failure of Allegro's product can reasonably be expected to cause bodily harm.

The information included herein is believed to be accurate and reliable. However, Allegro MicroSystems assumes no responsibility for its use; nor for any infringement of patents or other rights of third parties which may result from its use.

Copies of this document are considered uncontrolled documents.

For the latest version of this document, visit our website:

www.allegromicro.com