

Self-Calibrating Automatic-TPOS Camshaft Speed Sensor IC

FEATURES AND BENEFITS

- Allegro UC package with integrated EMC components reduces need for external EMI protection
- True target state recognition at device power-on (TPOS) with automatic TPOS self-programming capability
- EEPROM programming for performance optimization, temperature compensation, and production traceability
- Chopper stabilization reduces offset drift

PACKAGE:



3-pin SIP (suffix UC)

Not to scale

DESCRIPTION

The A16311PUCA is a True Power-On State camshaft sensor incorporating an advanced fully synchronous digital IC and EMC protection circuit all in a single sensing solution.

The A16311 is a single element Hall-effect sensor IC which, when paired with a back-biasing magnetic circuit, switches in response to magnetic signals induced by a ferromagnetic target. The IC contains a sophisticated digital circuit designed to match the temperature behavior of the back-biasing magnet (either SmCo or NdFeB). Advanced signal processing is used to provide zero-speed performance independent of installation air gap and is designed for the typical operating conditions found in automotive camshaft sensing applications. The resulting output of the device is a digital representation of the ferromagnetic target profile.

The A16311 is highly programmable with many options to allow for performance optimization to meet specific application requirements.

The A16311 is provided in a 3-pin SIP package (UCA) that is lead (Pb) free, with 100% matte tin leadframe plating.

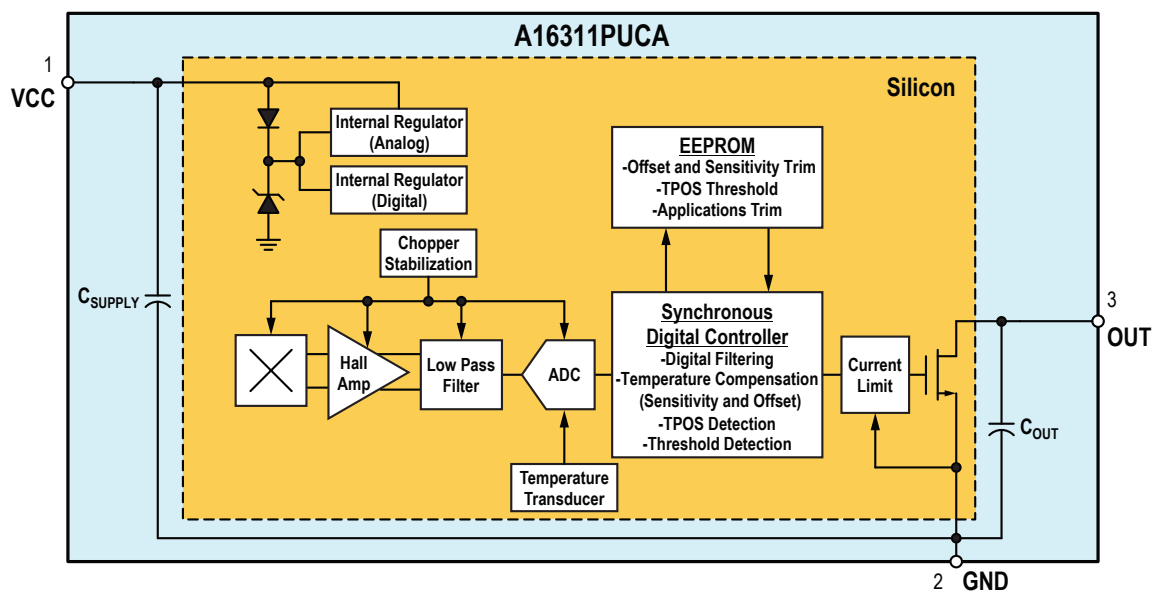

Functional Block Diagram

A16311

Self-Calibrating Automatic-TPOS Camshaft Speed Sensor IC

SELECTION GUIDE [1]

Part Number	Package	Packing
A16311PUCA-SLTMU12BAL	3-pin SIP	13-in. reel, 4000 pieces/reel



[1] Not all combinations are available. Contact Allegro sales for availability and pricing of custom programming options.

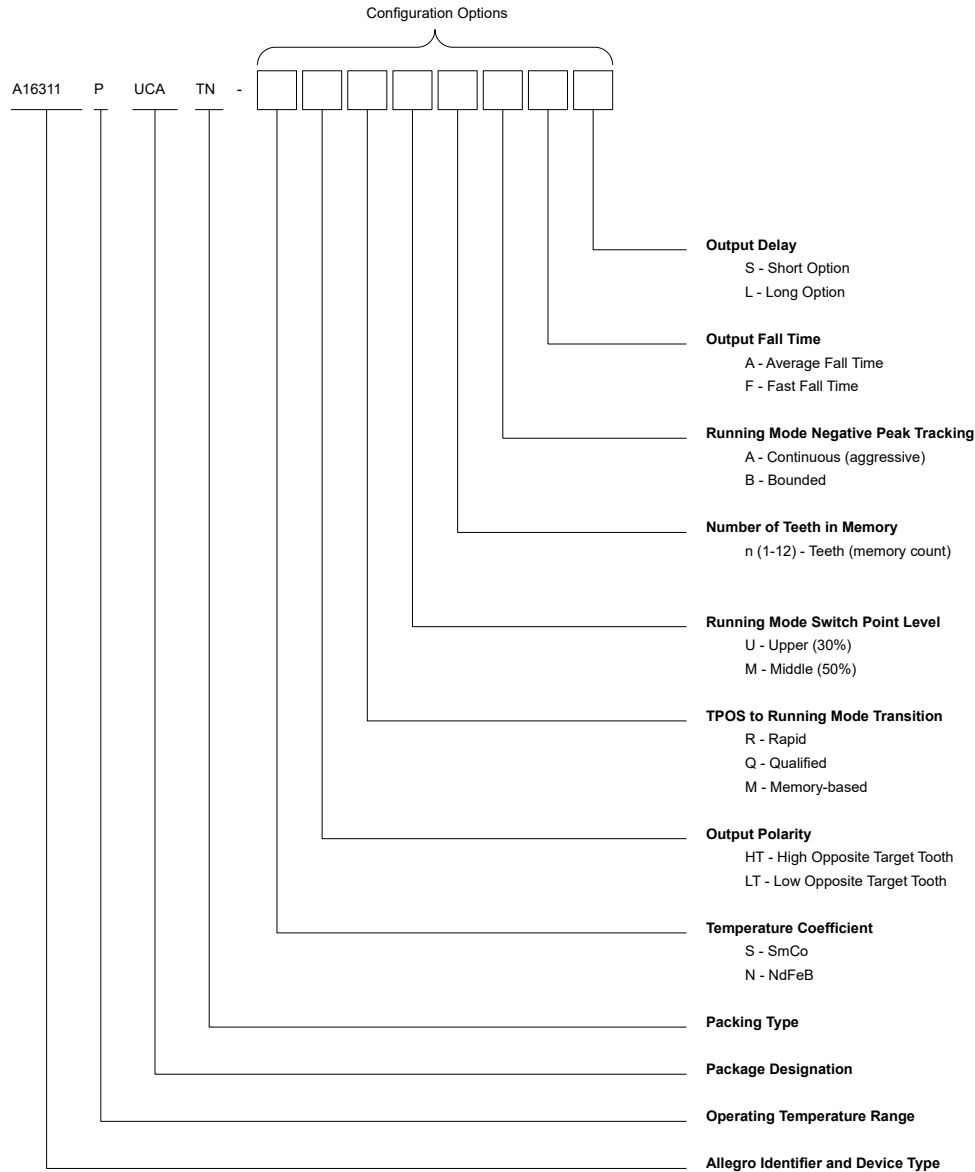

ABSOLUTE MAXIMUM RATINGS

Characteristic	Symbol	Notes	Rating	Units
Supply Voltage	V_{CC}		27	V
Reverse Supply Voltage	V_{RCC}		-18	V
Output Voltage	V_{OUT}		27	V
Reverse Output Voltage	V_{ROUT}	$R_{PU} \geq 1000 \Omega$	-0.5	V
Output Current	I_{OUT}	Internal current limiting is intended to protect the device from output short circuits, but is not intended for continuous operation.	25	mA
Reverse Output Current	I_{ROUT}	$V_{OUT} > -0.5 \text{ V}, T_A = 25^\circ\text{C}$	-50	mA
Operating Ambient Temperature	T_A	Range P	-40 to 160	$^\circ\text{C}$
Maximum Junction Temperature	$T_{J(max)}$	Contact Allegro for extended junction temperature data	170	$^\circ\text{C}$
Storage Temperature	T_{stg}		-65 to 170	$^\circ\text{C}$

INTERNAL DISCRETE COMPONENT RATINGS

Symbol	Characteristic	Rating	Units
C_{SUPPLY}	Nominal Capacitance	220	nF
C_{OUT}	Nominal Capacitance	1.8	nF

Pinout Diagram

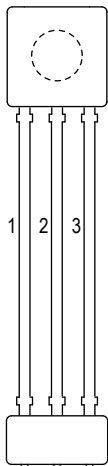

Terminal List

Number	Name	Function
1	VCC	Supply voltage
2	GND	Ground
3	VOUT	Device Output

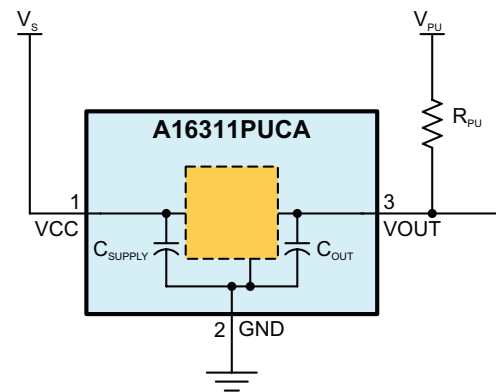
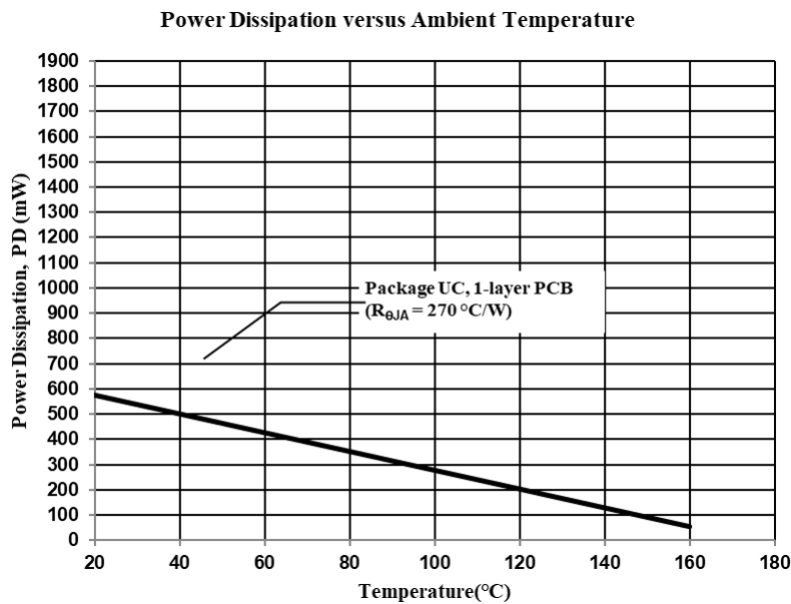
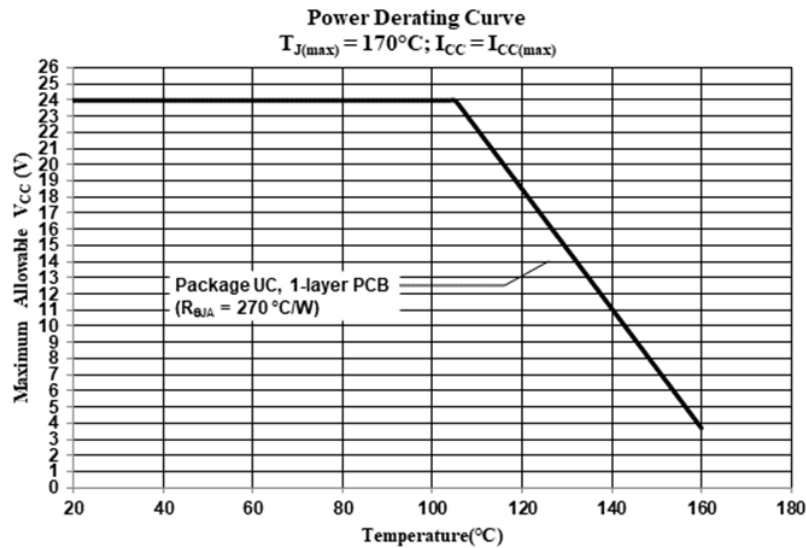

Figure 1: Minimum Application Circuit

THERMAL CHARACTERISTICS: May require derating at maximum conditions

Characteristic	Symbol	Test Conditions [1]	Value	Unit
Package Thermal Resistance	$R_{\theta JA}$	1-layer PCB with copper limited to solder pads	270	$^{\circ}C/W$

[1] Additional thermal information available on the Allegro website.



OPERATING CHARACTERISTICS: Valid over operating ranges, unless otherwise specified

Characteristics	Symbol	Test Conditions	Min.	Typ. ^[1]	Max.	Unit	
ELECTRICAL CHARACTERISTICS							
Supply Voltage	V_{CC}	Continuous operation, $T_J < T_{J(MAX)}$	3.3	–	24	V	
Supply Zener Clamp Voltage	$V_{Zsupply}$	$I_{CC} = I_{CC(MAX)} + 3 \text{ mA}$	27	–	–	V	
Reverse Supply Zener Clamp Voltage	$V_{RZsupply}$	$I_{CC} = -3 \text{ mA}$, $T_A = 25^\circ\text{C}$	–	–	-18	V	
Supply Current	I_{CC}		5	7	10	mA	
OUTPUT STAGE CHARACTERISTICS							
Output On Voltage	$V_{OUT(SAT)}$	$I_{OUT} = 5 \text{ mA}$, Output = on state ($V_{OUT} = \text{Low}$)	–	–	250	mV	
		$I_{OUT} = 15 \text{ mA}$, Output = on state ($V_{OUT} = \text{Low}$)	–	–	550	mV	
Output Zener Clamp Voltage	$V_{Zoutput}$	$I_{OUT} = 3 \text{ mA}$, $T_A = 25^\circ\text{C}$	27	–	–	V	
Output Current Limit	$I_{OUT(LIM)}$	Output = on state ($V_{OUT} = \text{Low}$)	30	–	80	mA	
Output Leakage Current	$I_{OUT(OFF)}$	$V_{OUT} = 24 \text{ V}$, Output = off state ($V_{OUT} = \text{High}$)	–	–	10	μA	
Output Rise Time	t_r	Measured 10% to 90% of V_{OUT} ; $R_{PU} = 1 \text{ k}\Omega$; $V_{PU} = 5 \text{ V}$	–	4	–	μs	
Output Fall Time	t_f	Measured 90% to 10% of V_{OUT} ; $R_{PU} = 1 \text{ k}\Omega$; $V_{PU} = 5 \text{ V}$	A fall time option	2.5	5	9	μs
			F fall time option	0.5	1.2	2.5	μs
		Measured 90% to 10% of V_{OUT} ; $R_{PU} = 1 \text{ k}\Omega$; $V_{PU} = 12 \text{ V}$	A fall time option	–	8	–	μs
			F fall time option	–	2	–	μs

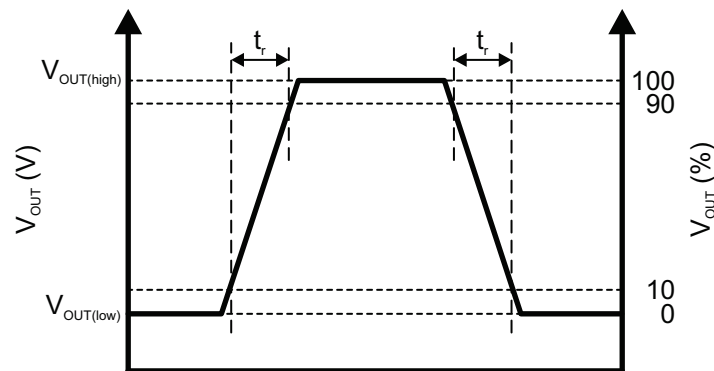

Figure 2: Output Rise Time and Output Fall Time

^[1] Typical values are at $T_A = 25^\circ\text{C}$ and $V_{CC} = 12 \text{ V}$. Performance may vary for individual units, within the specified maximum and minimum limits.

OPERATING CHARACTERISTICS (continued): Valid over operating ranges, unless otherwise specified

Characteristics	Symbol	Note	Min.	Typ.	Max.	Unit	
PERFORMANCE CHARACTERISTICS							
Operating Magnetic Input	B_{pk-pk}	Refer to Figure 4	$T_A = 25^\circ\text{C}$	46	–	400	G
			$T_A = 160^\circ\text{C}$	36	–	400	G
Operating Magnetic Range	B	Refer to Figure 4	0	–	400	G	
TPO Drift	$B_{TPOdrift}$	TPOS guaranteed	$B \leq 100\text{ G}$	–20	–	20	G
			$B > 100\text{ G}$	–20	–	20	%
Signal Bandwidth	BW	Equivalent to –3 dB cutoff frequency	–	8	–	kHz	
Magnetic Temperature Coefficient	TC_{MAG}	Optimized value, for SmCo	–	–0.03	–	%/°C	
		Optimized value, for NeFeB	–	–0.12	–	%/°C	
Phase Delay [2]	ΔEIT_{SRELF}	Electrical falling edges; $R_{PU} = 1\text{ k}\Omega$, $V_{PU} = 5\text{ V}$	F fall time, Delay Option 1	–	19.67	–	μs
			A fall time, Delay Option 1	–	26.00	–	μs
			F fall time, Delay Option 2	–	40.00	–	μs
			A fall time, Delay Option 2	–	46.67	–	μs
POWER-ON CHARACTERISTICS							
Power-On Time [3]	t_{PO}	$V_{CC} > V_{CC(MIN)}$	–	–	1	ms	
TPOS Mode		Number of mechanical edges after power-on with output switching on TPOS threshold	R Option	–	1	2	edge
			Q Option	2	–	3	edge
			M Option	–	–	$2+2n$ [4]	edge
Learning Mode		Number of target teeth after TPOS Mode with reduced accuracy threshold-based output switching	R Option	–	–	n [4]	tooth
			Q Option	–	–	n [4]	tooth
			M Option	–	–	0	tooth
Startup Hysteresis		Power-on over valley; magnetic signal movement to generate output switching, signal below and not crossing TPO threshold; $T_A = 25^\circ\text{C}$	R option	15	–	–	G
		Power-on over tooth; magnetic signal movement to generate output switching, signal above and not crossing TPO threshold; $B_{pk-pk} > 60\text{ G}$	R option	–	$B_{pk-pk} \times 0.375$	–	

[2] Phase Delay is the change in edge position at detection, through the full operational tooth speed range for a single device at a single temperature and installation air gap.

[3] Power-On Time consists of the time from when V_{CC} rises above $V_{CC(MIN)}$ until a valid output state is realized.

[4] n = selected memory count for running mode positive peak tracking.

OPERATING CHARACTERISTICS (continued): Valid over operating ranges, unless otherwise specified

Characteristics	Symbol	Note	Min.	Typ.	Max.	Unit	
OPERATING MODE CHARACTERISTICS							
Output Polarity	V_{OUT}	Opposite target tooth, connected as in Figure 1	LT option	Low		V	
			HT option	High		V	
		Opposite target valley, connected as in Figure 1	LT option	High		V	
			HT option	Low		V	
Threshold Update Memory		Number of target teeth (peaks) stored in memory for threshold update algorithm	1	–	12	tooth	
Operate Point [5]	B_{OP}	% of peak-to-peak, referenced to tooth signal	U option	–	30	–	%
			M option	–	50	–	%
Release Point [5]	B_{RP}	% of peak-to-peak, referenced to tooth signal	U option	–	30	–	%
			M option	–	50	–	%
Running Mode Hysteresis	$B_{HYS(int)}$	% of peak-to-peak signal	5	10	15	%	
Maximum Allowable Signal Reduction	B_{reduce}	Reduction in magnetic signal amplitude between two consecutive peaks; all specifications within range	–	–	$B_{OP} - 15\%$	%	
		Reduction in magnetic signal amplitude between two consecutive peaks; output switches, accuracy performance not guaranteed	–	–	$B_{OP} - 5\%$	%	

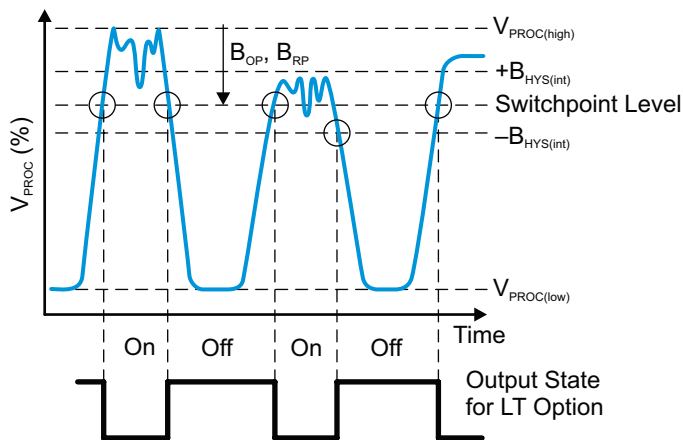

Figure 3: Switch Points with Internal Hysteresis

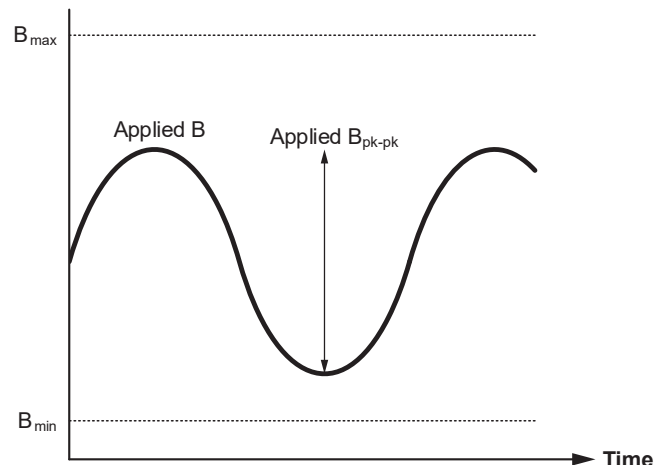

Figure 4: Input Signal Definition

[5] Custom programmable switch point options are also available, allowing independently programmable B_{OP} and B_{RP} between 30% and 50% with 1.56% resolution.

FUNCTIONAL DESCRIPTION

Sensing Technology

The A16311PUCA contains a single-chip Hall-effect sensor IC, a 3-pin leadframe with integrated EMC protection components. The IC includes a self-calibrating, chopper-stabilized Hall element that senses differences in magnetic field strength induced by ferromagnetic target teeth and valleys when coupled with a back-biasing magnet. The sensor generates a digital output signal that is representative of the target features, independent of the direction of target rotation or rotational orientation. The Hall transducer and the electronics are integrated on the same silicon substrate by a proprietary BiCMOS process. Changes in temperature do not negatively affect this device due to the stable amplifier design and advanced digital temperature compensation. The IC also contains a voltage regulator that provides undervoltage lockout and supply noise rejection over the operating voltage range.

Output Polarity

The polarity of the output with north pole of back biasing pellet toward IC is selectable to be either low opposite target teeth (*LT* option) or high opposite target teeth (*HT* option). See Figure 5.

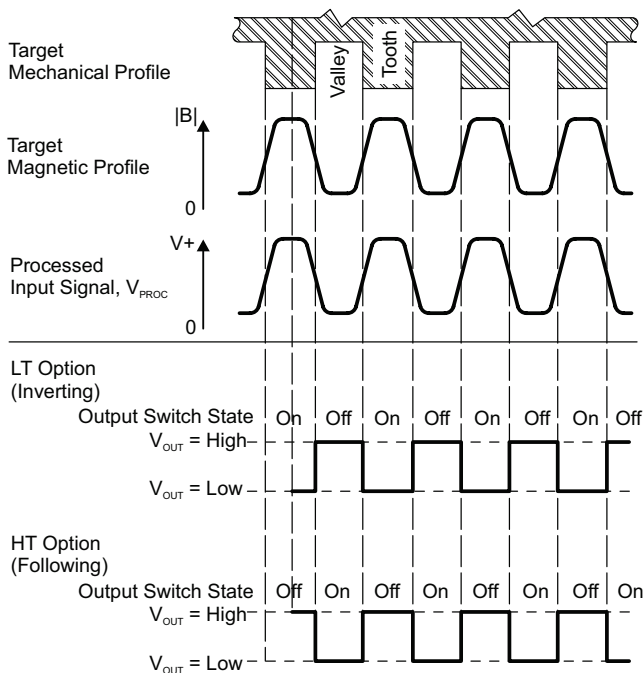

Figure 5: Output Polarity with north pole of back-biasing pellet toward IC (when connected as shown in Figure 1)

Threshold Update

The A16311PUCA has two sets of programmable options that determine the threshold update used to establish running mode switching levels. The positive peak threshold update is set to n teeth, which is programmable between one and twelve. The negative peak threshold update can either be set to continuous or bounded update.

With single tooth update ($n = 1$), the switching threshold for a tooth is established based on the measured peak value of the previous tooth. This option can be used with targets having any number of teeth and is comparable to the continuous update mode used on many Allegro sensors.

When $n = 2$ through 12, the device uses memory-based update. Peak information from the last n teeth is stored in on-chip memory. Switching thresholds for the upcoming tooth are established based on the stored information from n teeth earlier. When n is matched to the number of teeth on the target, this allows for optimized switch points based on the same tooth from the previous revolution of the target. The programmable threshold update results in improved output switching accuracy on targets with runout and tooth-to-tooth variation (including narrow valleys).

With continuous update (A option), the switching threshold for a tooth is based on the measured valley value of the previous tooth. This option provides backwards compatibility equivalent to some older generations of Allegro TPOS camshaft cells.

With bounded update (B option), large tooth-to-tooth changes in the negative peak tracking are filtered out and not applied to switching threshold generation. This option provides improved output accuracy on camshaft targets with narrow valley widths.

Switch Points and Hysteresis

The running mode switch points in the A16311 are established dynamically as a percentage of the tracked peaks and valleys, as described in the Threshold Update section. Both the operate point (B_{OP}) and the release point (B_{RP}) are independently customer programmable.

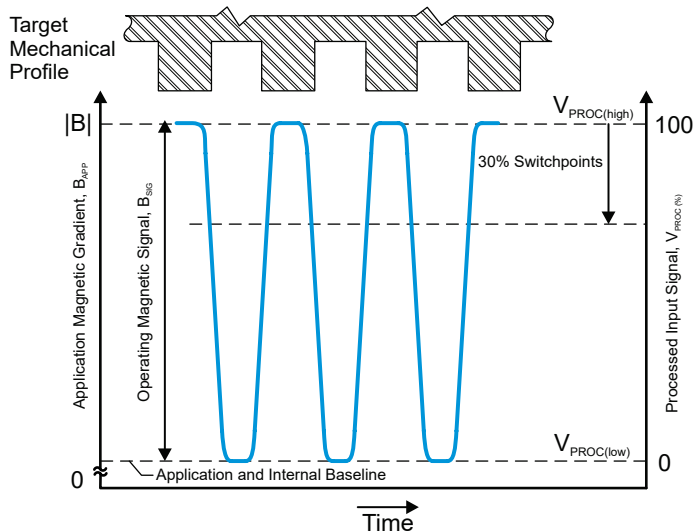

Figure 6: Switch Point Options

Internal hysteresis allows for high performance switching accuracy on both rising and falling edges while maintaining immunity to false switching on noise, vibration, backlash, or other transient events. See Figure 3.

Operating Modes

TPOS MODE

After power-on, the output state is determined by the level of the detected magnetic field relative to the fixed-gauss TPOS threshold, which is programmed at Allegro. The device remains in TPOS Mode for a number of edges that is dependent on the TPOS to Running mode transition option selected: rapid (R option), qualified (Q option), or memory-based (M option).

With the rapid option, once the magnetic signal movement exceeds a fixed startup hysteresis value, the device immediately transitions to calibration mode and threshold-based switching. The R option provides the fastest transition to running mode

thresholds, but in certain startup scenarios can result in a large difference in output accuracy between the first edge and the same running mode edge.

With the qualified option, the device remains in TPOS mode for at least two edges before transitioning to running mode. The Q option provides the lowest worst-case output accuracy difference between the first edge and subsequent running mode edges.

With the memory-based option, the device remains in TPOS mode for n teeth, which is programmable between one and twelve, to guarantee it has correctly captured enough peaks to fill the running mode threshold memory. The M option provides the slowest transition to running mode thresholds, but provides best runout capability.

CALIBRATION MODE

In calibration mode, the A16311 uses threshold-based switching with continuous update. This ensures that all teeth and valleys are captured correctly, but provides slightly reduced accuracy relative to running mode. The device stays in calibration mode long enough to guarantee it has correctly captured enough peaks to fill the running mode threshold memory. After calibration mode is complete, the device transitions to running mode.

RUNNING MODE

In running mode, the A16311 uses threshold-based switching with internal hysteresis as described in the previous Threshold Update and Switch Points and Hysteresis sections. The threshold update is intended to optimize output switching accuracy when used with common camshaft targets, including cases with runout and narrow target valleys.

WATCHDOG

The A16311 has a peak detector continuously tracking the magnetic signal. If a sudden large signal change causes the sensor output to stop switching but the peak detector continues to detect valid signal movement, the watchdog will be triggered. When it is triggered, the sensor performs a self-reset and returns to initial startup hysteresis mode to regain output switching.

Automatic TPOS Threshold

The A16311 has automatic threshold update to optimize accuracy during TPOS Mode.

The threshold update is active for the first 25 mechanical edges after power on.

POWER DERATING

The device must be operated below the maximum junction temperature of the device ($T_{J(max)}$). Under certain combinations of peak conditions, reliable operation may require derating supplied power or improving the heat dissipation properties of the application. This section presents a procedure for correlating factors affecting operating T_J . (Thermal data is also available on the Allegro MicroSystems website.)

The Package Thermal Resistance ($R_{\theta JA}$) is a figure of merit summarizing the ability of the application and the device to dissipate heat from the junction (die), through all paths to the ambient air. Its primary component is the Effective Thermal Conductivity (K) of the printed circuit board, including adjacent devices and traces. Radiation from the die through the device case ($R_{\theta JC}$) is relatively small component of $R_{\theta JA}$. Ambient air temperature (T_A) and air motion are significant external factors, damped by overmolding.

The effect of varying power levels (Power Dissipation, P_D), can be estimated. The following formulas represent the fundamental relationships used to estimate T_J at P_D .

$$P_D = V_{IN} \times I_{IN} \quad (1)$$

$$\Delta T = P_D \times R_{\theta JA} \quad (2)$$

$$T_J = T_A + \Delta T \quad (3)$$

For example, given common conditions such as:

$$T_A = 25^\circ C$$

$$V_{CC} = 12 V$$

$$R_{\theta JA} = 270^\circ C/W$$

$$I_{CC} = 7 mA$$

Then:

$$P_D = V_{CC} \times I_{CC} = 12 V \times 7 mA = 84 mW$$

$$\Delta T = P_D \times R_{\theta JA} = 84 mW \times 270^\circ C/W = 22.7^\circ C$$

$$T_J = T_A + \Delta T = 25^\circ C + 22.7^\circ C = 47.7^\circ C$$

A worst-case estimate, $P_{D(max)}$, represents the maximum allowable power level, $V_{CC(max)}$, $I_{CC(max)}$, without exceeding $T_{J(max)}$, at a selected $R_{\theta JA}$ and T_A .

Example: Reliability for V_{CC} at $T_A = 160^\circ C$.

Observe the worst-case ratings for the device, specifically:

$$R_{\theta JA} = 270^\circ C/W$$

$$T_{J(max)} = 170^\circ C$$

$$V_{CC(max)} = 24 V$$

$$I_{CC} = 10 mA.$$

Calculate the maximum allowable power level, $P_{D(max)}$. First, invert equation 3:

$$\Delta T_{(max)} = T_{J(max)} - T_A = 170^\circ C - 160^\circ C = 10^\circ C$$

This provides the allowable increase to T_J resulting from internal power dissipation. Then, invert equation 2:

$$P_{D(max)} = \Delta T_{(max)} \div R_{\theta JA} = 10^\circ C \div 270^\circ C/W = 37 mW$$

Finally, invert equation 1 with respect to voltage:

$$V_{CC(est)} = P_{D(max)} \div I_{CC(max)} = 37 mW \div 10 mA = 3.7 V$$

The result indicates that, at T_A , the application and device can dissipate adequate amounts of heat at voltages $\leq V_{CC(est)}$.

Compare $V_{CC(est)}$ to $V_{CC(max)}$. If $V_{CC(est)} \leq V_{CC(max)}$, then reliable operation between $V_{CC(est)}$ and $V_{CC(max)}$ requires enhanced $R_{\theta JA}$. If $V_{CC(est)} \geq V_{CC(max)}$, then operation between $V_{CC(est)}$ and $V_{CC(max)}$ is reliable under these conditions.

Revision History

Number	Date	Description
–	November 13, 2019	Initial release

Copyright 2019, Allegro MicroSystems.

Allegro MicroSystems reserves the right to make, from time to time, such departures from the detail specifications as may be required to permit improvements in the performance, reliability, or manufacturability of its products. Before placing an order, the user is cautioned to verify that the information being relied upon is current.

Allegro's products are not to be used in any devices or systems, including but not limited to life support devices or systems, in which a failure of Allegro's product can reasonably be expected to cause bodily harm.

The information included herein is believed to be accurate and reliable. However, Allegro MicroSystems assumes no responsibility for its use; nor for any infringement of patents or other rights of third parties which may result from its use.

Copies of this document are considered uncontrolled documents.

For the latest version of this document, visit our website:

www.allegromicro.com