

Demo Board Schematic/Layout

SCHEMATIC

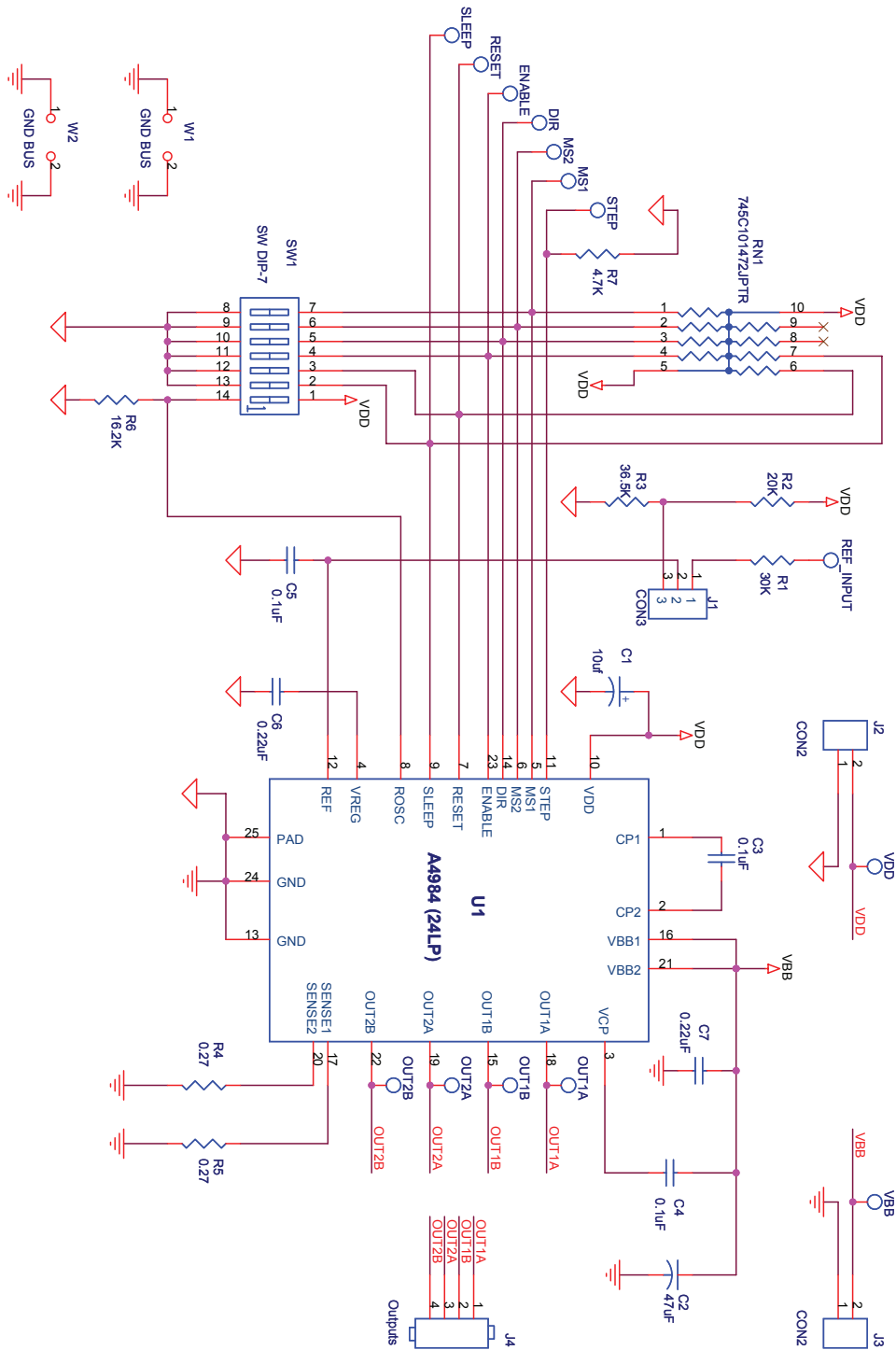

LAYOUT

ALL COMPONENTS MUST BE ROHS COMPLIANT.

USE LEAD FREE SOLDER

VIEW IS TOP SILKSCREEN

THIS BOARD HAS 4 LAYERS

MAKE W1 AND W2 WIRES A FINISHED HEIGHT OF .25" - .4" FROM THE BOARD.

PLACE BUMPS ON BOTTOM 4 CORNERS OF PC BOARD.

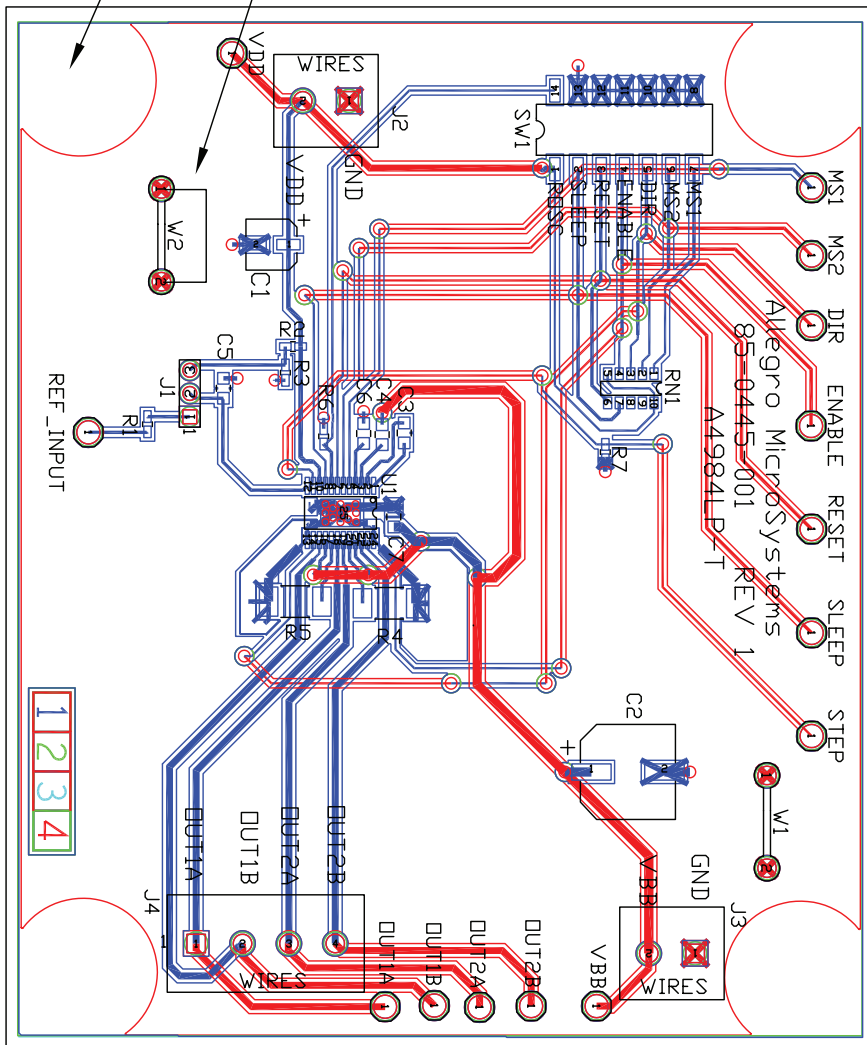

BILL OF MATERIALS

ALL COMPONENTS MUST BE ROHS COMPLIANT

Item	Qty	Part Reference	Value	Manufacturer	Manufacturer Number	Description	PCB Footprint
1	14	OUT1A,OUT1B, OUT2A,OUT2, STEP,MS1,MS2, DIR,ENABLE, RESET,SLEEP, REF_INPUT,VDD VBB,	TP	Keystone Electronics	5005	TEST POINT PC COMPACT .063"D RED	TP
2	1	C1	10uf	Panasonic-ECG	EEE-1EA100SR	CAP ELECT 10UF 25V VS SMD Case CodeC	smd400elec146
3	1	C2	47uf	Panasonic-ECG	EEE-1HA470P	CAP ELECT 47UF 50V VS SMD	smd400elec
4	3	C3,C4,C5	0.1uf	Kemet	C0805C104K3RACTU	CAP .10UF 25V CERAMIC X7R 0805	SMD0805
5	2	C6,C7	0.22uf	Taiyo Yuden	UMK212B7224KG-T	CAP CER .22UF 50V X7R 0805	SMD0805
6	1	J1	CON3	Samtec Inc.	TSW-103-07-G-S	Conn, Header, 3pos,.1" Sgl, Gold	header3
7	2	J2,J3	CON2	On Shore Technology	ED120/2DS	TERM BLOCK 5.08MM Vert 2pos	tb-ED120-2
8	1	J4	CON4	On Shore Technology	ED120/4DS	TERM BLOCK 5.08MM Vert 4pos	tb-ED120-4
9	1	RN1	4.7K	CTS Corporation Resistor/ Electrocomponents	745C101472JPTR	RES ARRAY 4.7K OHM 10TRM BSS SMD	SMD10P_126X50
10	1	R1	30K	Rohm	MCR03EZPFX3002	RES 30.0K OHM 1/10W 1% 0603 SMD	SMD0603
11	1	R2	20K	Rohm	MCR03EZPJ203	RES 20K OHM 1/10W 5% 0603 SMD	SMD0603
12	1	R3	36.5K	Yageo	RC0603FR-0736K5L	RES 36.5K OHM 1/10W 1% 0603 SMD	SMD0603
13	2	R4,R5	0.27	Panasonic - ECG	ERJ-1TRQFR27U	RES .27 OHM 1W 1% 2512 SMD	SMD2512
14	1	R6	16.2K	Rohm	MCR03EZPFX1622	RES 16.2K OHM 1/10W 1% 0603 SMD	SMD0603
15	1	R7	4.7K	Rohm	MCR03EZPFX4701	RES 4.70K OHM 1/10W 1% 0603 SMD	SMD0603
16	1	SW1	SW DIP 7	C&K Components	SD07H1SB	SWITCH DIP SPST SEALED 7POS SMD	smd_dip14_3
17	1	U1	A4984SLP	Allegro MicroSystems	A4984SLP	DMOS Microstepping Driver with Translator	tssop25
18	1	PCB	85-0445-001			A4984LP-T, Printed Circuit Board, ROHS	
19	4	Bumpson	3m/ESM		SJ5003	Bumpon, Hemisphere, Black Place on bottom 4 corners of PC board	
20	2	W1, W2	GND BUS	any	any	20 AWG Solid Bus Wire, about 1"long Finished height of .25"-.4" from board	tp4
21	1	for J1	Shunt	Sullins Electronics	STC02SYAN	CONN,JUMPER SHORTING TIN	

Replacement for capacitors and resistors must be equivalent to listed component.

Revision History

Number	Date	Description
–	September 6, 2016	Initial release

Copyright ©2016, Allegro MicroSystems, LLC

Allegro MicroSystems, LLC reserves the right to make, from time to time, such departures from the detail specifications as may be required to permit improvements in the performance, reliability, or manufacturability of its products. Before placing an order, the user is cautioned to verify that the information being relied upon is current.

Allegro's products are not to be used in any devices or systems, including but not limited to life support devices or systems, in which a failure of Allegro's product can reasonably be expected to cause bodily harm.

The information included herein is believed to be accurate and reliable. However, Allegro MicroSystems, LLC assumes no responsibility for its use; nor for any infringement of patents or other rights of third parties which may result from its use.

For the latest version of this document, visit our website:

www.allegromicro.com

