

Two-Wire AC-Coupled Differential Sensor IC with Integrated Filter Capacitor

FEATURES AND BENEFITS

- Integrated tracking capacitor
- Integrated capacitor reduces requirements for external EMI protection components (UB package)
- Used for sensing motion of ring magnet or ferrous targets
- Wide operating temperature range
- Operation with magnetic input signal frequency from 8 Hz to 20 kHz
- Large effective air gaps
- 3.5 to 24.0 V supply operating range
- Reverse battery protection
- Resistant to mechanical and thermal stress

PACKAGES:

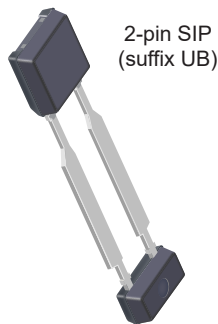
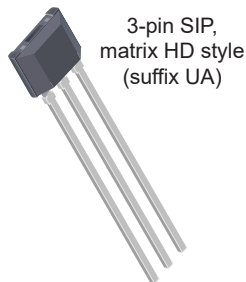

Not to scale

DESCRIPTION

The A17201 is an AC-coupled Hall-effect sensor IC which includes monolithic integrated circuits that switch in response to changing differential magnetic fields created by rotating ring magnets or, when coupled with a magnet, by ferrous targets. This device also includes an integrated tracking capacitor that provides the high accuracy of analog sensing without an external filter capacitor. This reduces cost and components, while improving the reliability of the final sensor solution.

Magnetic field changes affect the two integrated Hall transducers and then are differentially amplified on the chip. Differential design provides immunity to radial vibration, within the device operating air gap range, by rejection of this common-mode signal change. Steady-state system offsets are eliminated using an on-chip differential bandpass filter with integrated capacitor. This filter also provides relative immunity to interference from electromagnetic sources. The device uses advanced temperature compensation for the high-pass filter, sensitivity, and Schmitt trigger switchpoints to guarantee optimal operation to low frequencies over a wide range of air gaps and temperatures.

Continued on next page...

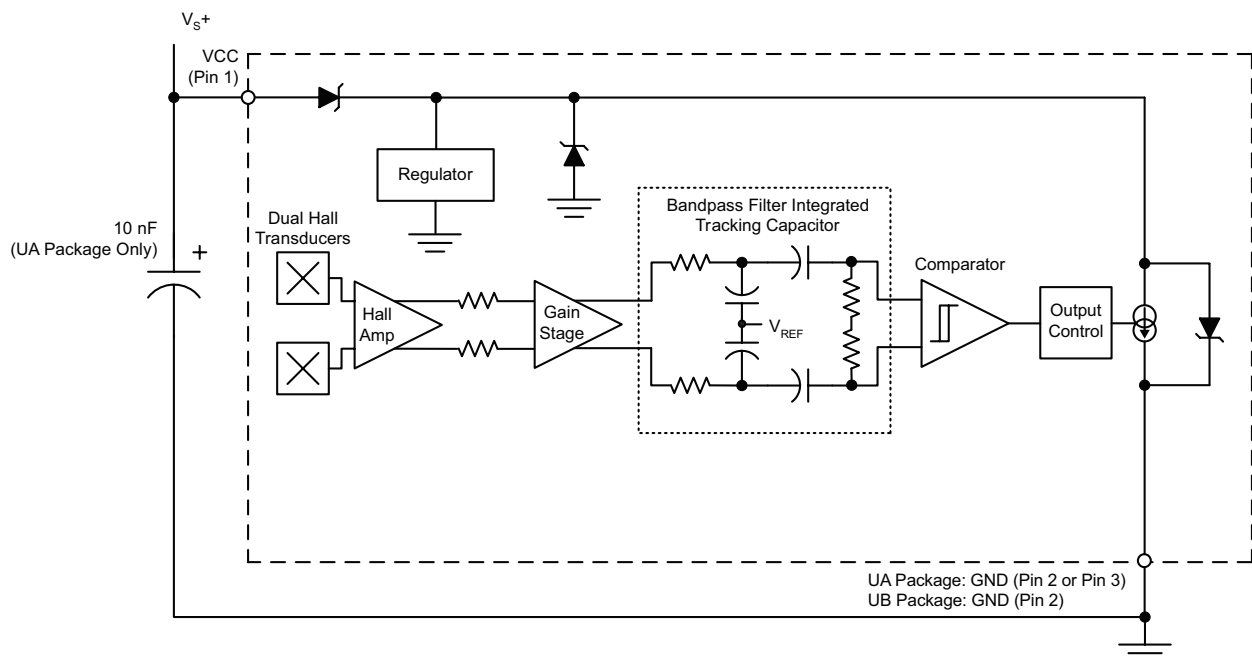

Figure 1: Functional Block Diagram

DESCRIPTION (continued)

The device includes: a voltage regulator, two Hall transducers, temperature compensating circuitry, a signal conditioning amplifier, bandpass filter, Schmitt trigger, and an output control. The on-board regulator permits operation with supply voltages from 3.5 to 24 V.

The regulated current output is configured for two-wire interface circuitry and is ideally suited for obtaining speed information in

wheel speed applications. The device packages have an operating ambient temperature range of -40°C to 150°C , and are provided in a 3-pin plastic SIP (suffix UA) or a 2-pin plastic SIP (suffix UB). Both packages are lead (Pb) free, with 100% matte-tin-plated leadframes.



SELECTION GUIDE

Part Number	Package	Packing [1]	Operating Ambient Temperature Range, T_A ($^{\circ}\text{C}$)	Supply Current	
				$I_{CC(Low)}$ min	$I_{CC(Low)}$ max
A17201LUAA	3-pin through hole SIP	Bulk, 500 pieces per bag	-40 to 150	3	7
A17201LUBBTN	2-pin through hole SIP	4000 pieces per 13-inch reel	-40 to 150	3	7

[1] Contact Allegro for additional packing options.

ABSOLUTE MAXIMUM RATINGS

Characteristic	Symbol	Notes	Rating	Unit
Supply Voltage	V_{CC}		28	V
Reverse Supply Voltage	V_{RCC}		-18	V
Operating Ambient Temperature	T_A	Range L	-40 to 150	$^{\circ}\text{C}$
Maximum Junction Temperature	$T_{J(MAX)}$		165	$^{\circ}\text{C}$
Storage Temperature	T_{stg}		-65 to 170	$^{\circ}\text{C}$

PINOUT DIAGRAMS AND TERMINAL LIST

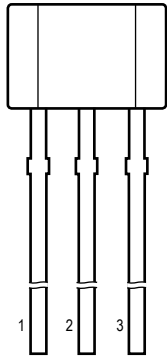

**UA Package
Pinout Diagram**

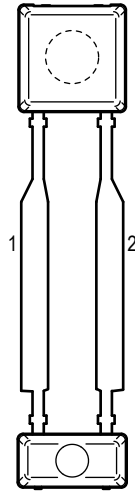

**UB Package
Pinout Diagram**

Terminal List

Name	Number		Description
	UA Package	UB Package	
VCC	1	1	Supply Voltage
GND	2	2	Ground
GND	3	–	Ground

INTERNAL DISCRETE CAPACITOR RATINGS (UB PACKAGE ONLY)

Characteristic	Symbol	Test Conditions	Value (Typ.)	Unit
Nominal Capacitance	C _{SUPPLY}	Connected between VCC and GND	10	nF

OPERATING CHARACTERISTICS: Valid throughout full operating and temperature ranges, unless otherwise noted

Characteristics	Symbol	Test Conditions	Min.	Typ. [1]	Max.	Unit
ELECTRICAL CHARACTERISTICS						
Supply Voltage [2]	V_{CC}	Operating, $T_J < T_{J(MAX)}$	3.5	12	24	V
Reverse Supply Current [3]	I_{RCC}	$V_{CC} = -18$ V	–	–	–1	mA
Supply Zener Current	$I_{ZSUPPLY}$	$V_{CC} = 28$ V	–	–	19	mA
Supply Zener Clamp Voltage	$V_{ZSUPPLY}$	$I_{CC} = I_{CC(MAX)} + 3$ mA, $T_A = 25^\circ\text{C}$	28	33	37	V
Supply Current	$I_{CC(LOW)}$	Low-current state	3	–	7	mA
	$I_{CC(HIGH)}$	High-current state	12.0	–	16.0	mA
RESPONSE CHARACTERISTICS						
Power-On Time [4][5]	t_{PO}	$V_{CC} > V_{CC(MIN)}$	–	7	15	ms
Settling Time [5][6]	$t_{SETTLING}$	$f_{Bdiff} \geq 100$ Hz	–	–	310	ms
Response Time [5]	$t_{RESPONSE}$	Equal to $t_{PO} + t_{SETTLING}$; $f_{Bdiff} \geq 100$ Hz	–	–	325	ms
Upper Corner Frequency [7]	f_{CU}	–3 dB, single pole	20	–	–	kHz
Lower Corner Frequency [7]	f_{CL}	–3 dB, single pole	–	–	8	Hz
OUTPUT CHARACTERISTICS [8]						
Output Slew Rate Time	dI/dt	No load (UA package only)	7	–	–	mA/ μ s
Output Rise Time	t_r	$\Delta I/\Delta t$ from 10% to 90% I_{CC} level; corresponds to measured output slew rate with C_{SUPPLY}	–	–	5.5	μ s
Output Fall Time	t_f	$\Delta I/\Delta t$ from 90% to 10% I_{CC} ; corresponds to measured output slew rate with C_{SUPPLY}	–	–	5.5	μ s
MAGNETIC CHARACTERISTICS						
Operate Point [9]	B_{OP}	B_{diff} increasing, $f_{Bdiff} = 200$ Hz, $B_{diff} = 50$ G _{p-p} , I_{CC} switches from low to high	–	7	17.4	G
Release Point [8]	B_{RP}	B_{diff} decreasing, $f_{Bdiff} = 200$ Hz, $B_{diff} = 50$ G _{p-p} , I_{CC} switches from high to low	–17.4	–7	–	G
Hysteresis [8]	B_{HYS}	$f_{Bdiff} = 200$ Hz, $B_{diff} = 50$ G _{p-p}	–	14	–	G
Applied Magnetic Field [10]	B_{diff}	Differential p-p magnetic field	–	–	1250	G

[1] Typical values are at $T_A = 25^\circ\text{C}$ and $V_{CC} = 12$ V. Performance may vary for individual units, within the specified maximum and minimum limits.

[2] Maximum voltage must be adjusted for power dissipation and junction temperature; see Power Derating section.

[3] Negative current is defined as conventional current coming out of (sourced from) the specified device terminal.

[4] Time required to initialize device.

[5] See Definitions of Terms section.

[6] Time required for the output switchpoints to be within specification.

[7] The specification is based on statistical evaluation of a limited sample population.

[8] Load circuit is $R_L = 100$ Ω and $C_L = 10$ pF. Pulse duration measured at threshold of $((I_{CC(HIGH)} + I_{CC(LOW)}) / 2)$.

[9] For lower frequencies, the absolute values of B_{OP} , B_{RP} , and B_{HYS} may decrease due to delay induced by the high-pass filter.

[10] Exceeding the maximum magnetic field may result in compromised absolute accuracy.

THERMAL CHARACTERISTICS: May require derating at maximum conditions; see application information

Characteristic	Symbol	Test Conditions	Value	Units
Package Thermal Resistance	$R_{\theta JA}$	Package UA, 1-layer PCB with copper limited to solder pads	165	$^{\circ}\text{C}/\text{W}$
		Package UB, 1-layer PCB with copper limited to solder pads	213	$^{\circ}\text{C}/\text{W}$

Power Derating Curve

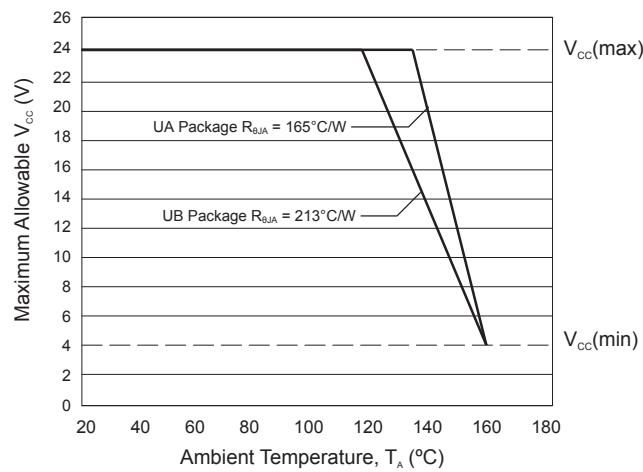

Power Dissipation versus Ambient Temperature

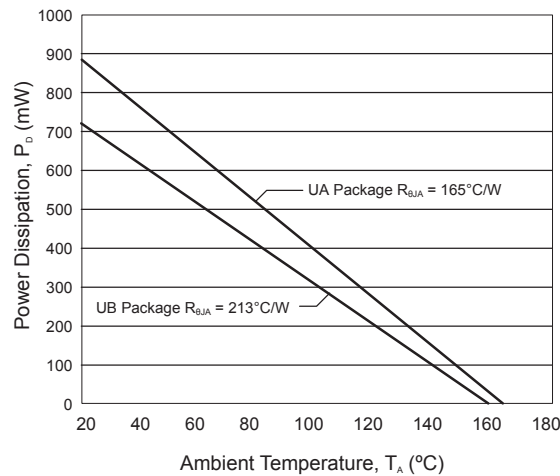

DEFINITION OF TERMS

The following provides additional information about some of the parameters cited. For additional information, visit the Allegro website at www.allegromicro.com.

Applied Magnetic Field, B_{diff} – The differential magnetic flux density, which is calculated as the arithmetic difference of the flux densities observed by each of the two Hall elements. f_{Bdiff} is the input signal frequency.

Output Off Switchpoint (Operate Point), B_{OP} – The value of increasing differential magnetic flux density at which the output signal, I_{CC} switches from $I_{CC(Low)}$ to $I_{CC(High)}$.

Output On Switchpoint (Release Point), B_{RP} – The value of decreasing differential magnetic flux density at which the output signal, I_{CC} from $I_{CC(High)}$ to $I_{CC(Low)}$.

Power-On Time, t_{PO} – The time needed by the device, after power is applied, to initialize all circuitry necessary for proper operation.

Settling Time, $t_{SETTLING}$ – The time required by the device, after t_{PO} , and after a valid magnetic signal has been applied, to provide proper output transitions. Settling time is a function of magnetic offset, offset polarity, signal phase, signal frequency, and signal amplitude.

Response Time, $t_{RESPONSE}$ – The total time required for generating zero-crossing output transitions after initialization (the sum of Power-On Time and Settling Time).

APPLICATIONS INFORMATION

The A17201 is a versatile high-precision differential sensor IC that can be used in a wide range of applications. Proper choice of the target material and shape, magnet material and shape, and assembly techniques enables large working air gaps and high switchpoint accuracy over the device operating temperature range.

Device Operation

The A17201 contains two integrated Hall transducers that are used to differentially respond to a magnetic field across the surface of the IC. As shown in Figure 2, the trigger switches the output signal I_{CC} high when the differential magnetic field crosses the B_{OP} level while increasing in strength (referred to as the positive direction) and switches the output signal, I_{CC} low when the differential magnetic field crosses B_{RP} while decreasing (the negative direction).

Start-Up

During power-on time, t_{PO} , the output signal, I_{CC} is high. Beyond this time, if the applied magnetic field, B_{diff} , is smaller than B_{HYS} , the switching state and output polarity are indeterminate. I_{CC} will be valid for $B_{diff} > B_{HYS}$, after the additional settling time, $t_{SETTLING}$, has also elapsed.

Delay

The bandpass filter induces delay in the output signal, I_{CC} , relative to the applied magnetic field, B_{diff} . Simulation data shown in the Characteristic Data section quantify the effect of the input signal amplitude on the phase shift of the output. Positive values of delay indicate a lagging output, while negative values indicate a leading output.

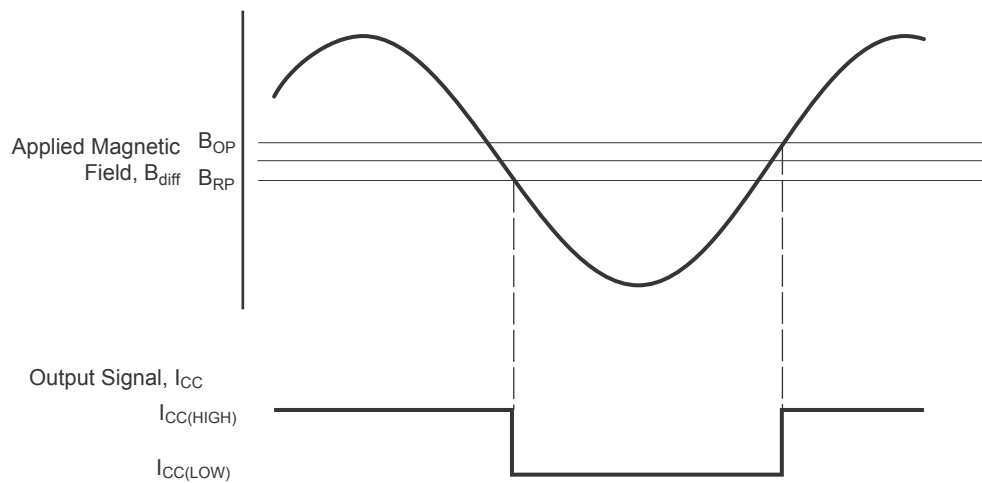

Figure 2: Typical Output Characteristic

AC-Coupled Operation

Steady-state magnet and system offsets are eliminated using an on-chip differential bandpass filter. The upper and lower cutoff frequencies of this patented filter are set using an internal integrated capacitor. The differential structure of this filter improves the ability of the IC to reject single-ended noise on the GND or VCC lines and, as a result, makes the device more resistant to EMI (electromagnetic interference) typically seen in hostile remote-sensing environments.

Power Supply Protection

The device contains an on-chip voltage regulator and can operate over a wide supply voltage range. In applications that operate the device from an unregulated power supply, transient protection must be added externally. For applications using a regulated line, EMI/RFI protection may still be required. The circuit shown in Figure 3 is the most basic configuration required for proper device operation.

Typical Circuit

A resistor sense, R_L , to exhibit two wire output between GND and Pin 2, is shown in Figure 3.

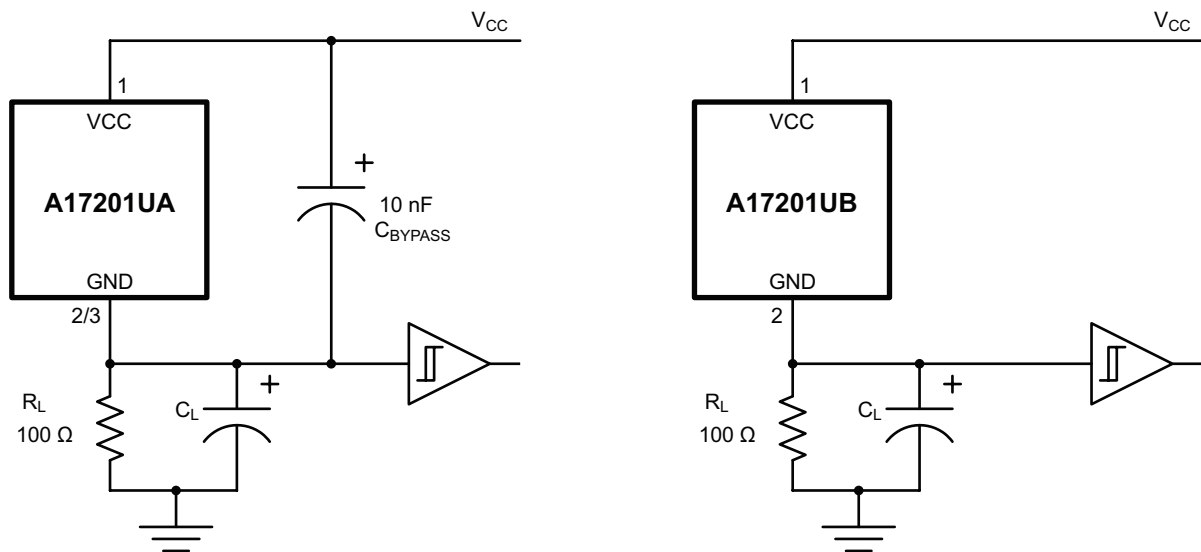

Figure 3: Typical Application Circuits

POWER DERATING

The device must be operated below the maximum junction temperature of the device, $T_{J(\max)}$. Under certain combinations of peak conditions, reliable operation may require derating supplied power or improving the heat dissipation properties of the application. This section presents a procedure for correlating factors affecting operating T_J . (Thermal data is also available on the Allegro MicroSystems Web site.)

The Package Thermal Resistance, $R_{\theta JA}$, is a figure of merit summarizing the ability of the application and the device to dissipate heat from the junction (die), through all paths to the ambient air. Its primary component is the Effective Thermal Conductivity, K , of the printed circuit board, including adjacent devices and traces. Radiation from the die through the device case, $R_{\theta JC}$, is relatively small component of $R_{\theta JA}$. Ambient air temperature, T_A , and air motion are significant external factors, damped by overmolding.

The effect of varying power levels (Power Dissipation, P_D), can be estimated. The following formulas represent the fundamental relationships used to estimate T_J , at P_D .

$$P_D = V_{IN} \times I_{IN} \quad (1)$$

$$\Delta T = P_D \times R_{\theta JA} \quad (2)$$

$$T_J = T_A + \Delta T \quad (3)$$

For example, given common conditions such as: $T_A = 25^\circ\text{C}$, $V_{CC} = 3.5\text{ V}$, $I_{CC} = 12\text{ mA}$, and $R_{\theta JA} = 165^\circ\text{C/W}$, then:

$$P_D = V_{CC} \times I_{CC} = 3.5\text{ V} \times 12\text{ mA} = 42\text{ mW}$$

$$\Delta T = P_D \times R_{\theta JA} = 42\text{ mW} \times 165^\circ\text{C/W} = 6.9^\circ\text{C}$$

$$T_J = T_A + \Delta T = 25^\circ\text{C} + 6.9^\circ\text{C} = 31.9^\circ\text{C}$$

A worst-case estimate, $P_{D(\max)}$, represents the maximum allowable power level ($V_{CC(\max)}$, $I_{CC(\max)}$), without exceeding $T_{J(\max)}$, at a selected $R_{\theta JA}$ and T_A .

Example: Reliability for V_{CC} at $T_A = 150^\circ\text{C}$, package UA, using single-layer PCB.

Observe the worst-case ratings for the device, specifically: $R_{\theta JA} = 165^\circ\text{C/W}$, $T_{J(\max)} = 165^\circ\text{C}$, $V_{CC(\max)} = 24\text{ V}$, and $I_{CC(\max)} = 16\text{ mA}$ (Note: $I_{CC(\text{LOW})} = 7\text{ mA}$, $I_{CC(\text{HIGH})} = 16\text{ mA}$ with a duty cycle of 50.0% and a worst case means I_{CC} of 11.5 mA).

Calculate the maximum allowable power level, $P_{D(\max)}$. First, invert equation 3:

$$\Delta T_{\max} = T_{J(\max)} - T_A = 165^\circ\text{C} - 150^\circ\text{C} = 15^\circ\text{C}$$

This provides the allowable increase to T_J resulting from internal power dissipation. Then, invert equation 2:

$$P_{D(\max)} = \Delta T_{\max} \div R_{\theta JA} = 15^\circ\text{C} \div 165^\circ\text{C/W} = 90\text{ mW}$$

Finally, invert equation 1 with respect to voltage:

$$V_{CC(\text{est})} = P_{D(\max)} \div I_{CC(\max)} = 90\text{ mW} \div 11.5\text{ mA} = 7.8\text{ V}$$

The result indicates that, at T_A , the application and device can dissipate adequate amounts of heat at voltages $\leq V_{CC(\text{est})}$.

Compare $V_{CC(\text{est})}$ to $V_{CC(\max)}$. If $V_{CC(\text{est})} \leq V_{CC(\max)}$, then reliable operation between $V_{CC(\text{est})}$ and $V_{CC(\max)}$ requires enhanced $R_{\theta JA}$. If $V_{CC(\text{est})} \geq V_{CC(\max)}$, then operation between $V_{CC(\text{est})}$ and $V_{CC(\max)}$ is reliable under these conditions.

PACKAGE OUTLINE DRAWING

For Reference Only – Not for Tooling Use

(Reference DWG-0000408, Rev. 4)
Dimensions in millimeters – NOT TO SCALE

Exact case and lead configuration at supplier discretion within limits shown

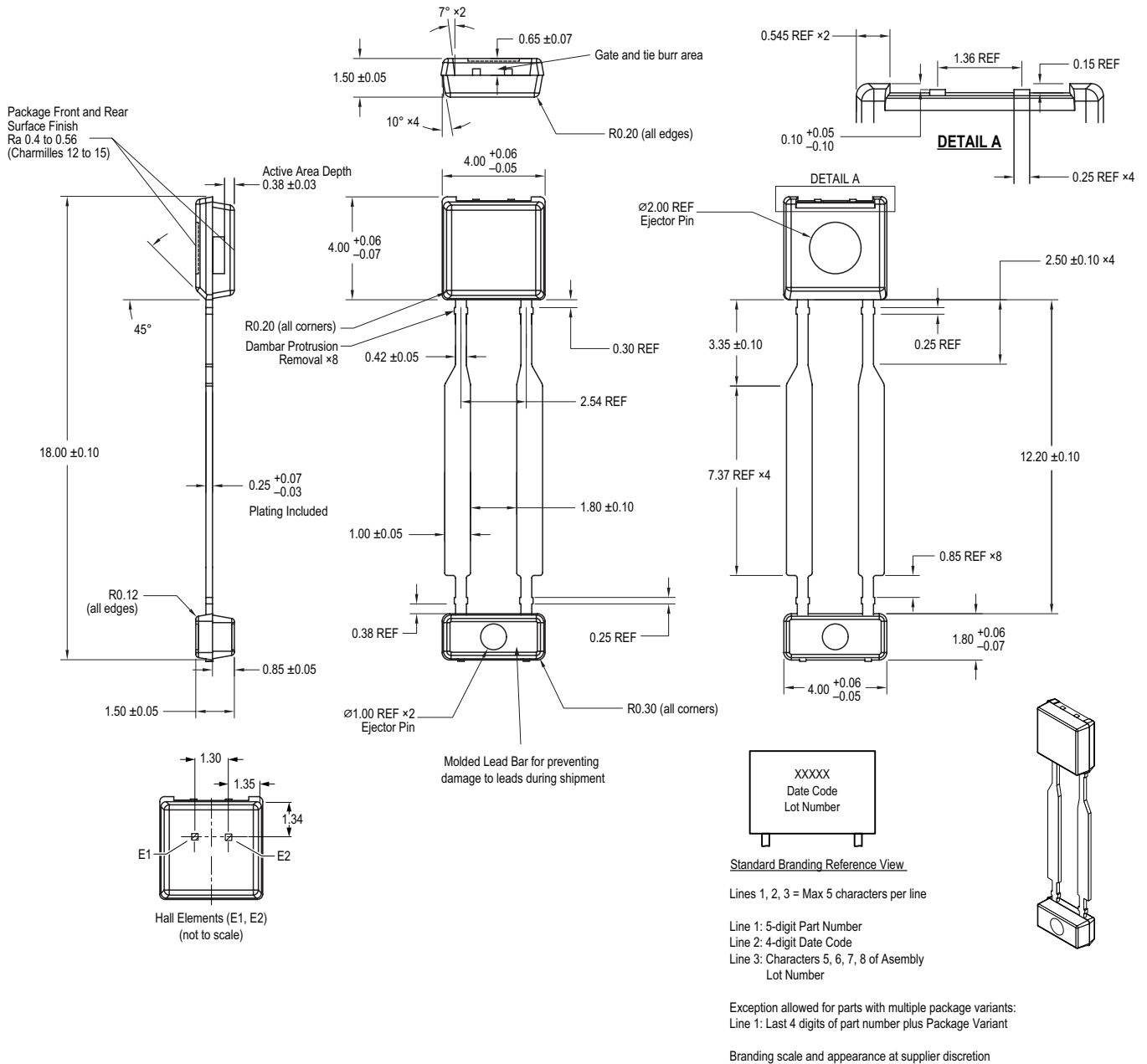

Figure 5: Package UB, 2-pin SIP

Revision History

Number	Date	Description
–	March 12, 2018	Initial release
1	September 4, 2018	Changed part number
2	November 30, 2018	Updated part numbers in selection guide
3	April 12, 2019	Updated selection guide (page 2) and supply current (page 4)
4	January 7, 2020	Updated capacitor values (pages 1, 38), part numbers (page 2), and Output Rise and Fall Time values (page 4)
5	March 2, 2022	Updated package drawing (page 11)

Copyright 2022, Allegro MicroSystems.

Allegro MicroSystems reserves the right to make, from time to time, such departures from the detail specifications as may be required to permit improvements in the performance, reliability, or manufacturability of its products. Before placing an order, the user is cautioned to verify that the information being relied upon is current.

Allegro's products are not to be used in any devices or systems, including but not limited to life support devices or systems, in which a failure of Allegro's product can reasonably be expected to cause bodily harm.

The information included herein is believed to be accurate and reliable. However, Allegro MicroSystems assumes no responsibility for its use; nor for any infringement of patents or other rights of third parties which may result from its use.

Copies of this document are considered uncontrolled documents.

For the latest version of this document, visit our website:

www.allegromicro.com