

GMR Speed and Direction Crankshaft Sensor with Three-Wire, Pulse-Width Output

FEATURES AND BENEFITS

- GMR technology integrates high sensitivity MR (magnetoresistive) sensor elements and high precision BiCMOS circuits on a single silicon integrated circuit, offering high accuracy, low magnetic field operation
- Allegro SM package with integrated EMC components reduces need for external EMI protection
- ASIL B safety design process with integrated diagnostics (pending assessment)
- Integrated back-biasing magnetic circuit
- Digital speed and direction output provides ferromagnetic target position information
- Enhanced algorithm for low jitter, high output accuracy performance, and vibration tolerance
- Center of package switching alignment option
- Programmable pulse location between center of target feature or edge of target feature
- EEPROM programmable performance optimizations and production traceability
- Target Profile Diagnostics™



PACKAGE:



3-pin SIP (suffix SM)

Not to scale

DESCRIPTION

The ATS16951PSM is an optimized giant magnetoresistance (GMR) integrated circuit (IC) and permanent magnet pellet combined with integrated EMC protection components to provide a user-friendly solution for digital gear tooth sensing. The small package can be easily assembled and used in conjunction with a wide variety of gear tooth targets and is intended for automotive crankshaft applications.

The device incorporates multiple GMR elements into a single IC that switches in response to differential magnetic signals created by a ferromagnetic target. The IC contains a sophisticated compensation circuit designed to eliminate detrimental effects of magnet and system offsets. Digital processing of the analog signal provides high performance independent of air gap and allows for dynamic adaptation of device performance to address the typical operating conditions found in automotive applications. Threshold hysteresis reduces the negative effects of any anomalies in the magnetic signal associated with system or target anomalies typically seen in many automotive applications.

The ATS16951PSM is being developed in accordance with ISO 26262 as a safety element out of context targeting ASIL B capability (pending assessment) for use in automotive safety-related systems when integrated and used in the manner prescribed in the applicable safety manual and datasheet.

The ATS16951PSM is available in a 3-pin package (SM) that is lead (Pb) free, with NiPdAu plating.

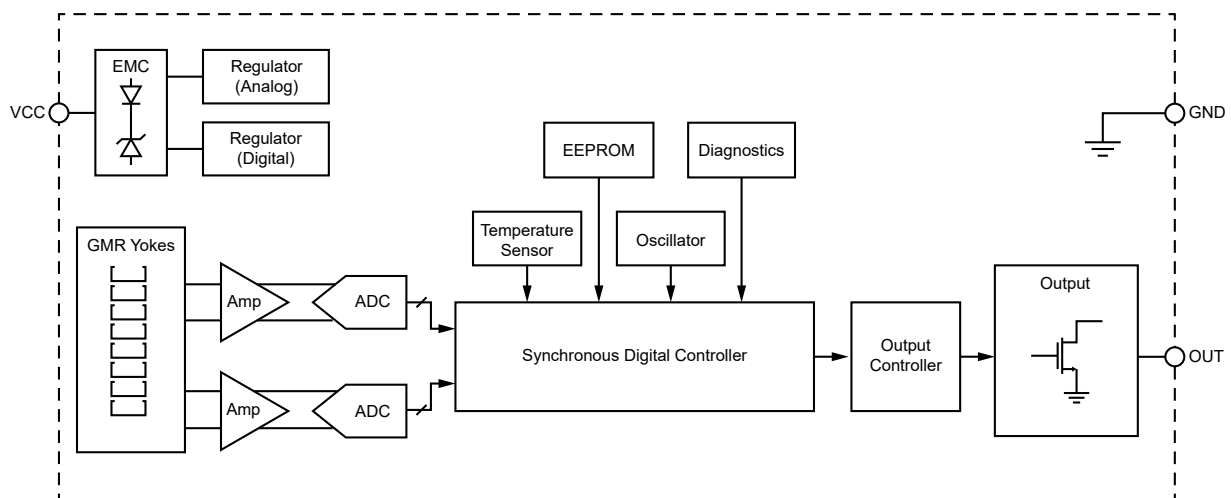

Figure 1: Functional Block Diagram

PROGRAMMABLE OPTIONS

Name	Available Selections*			
Sensor Output Protocol	Pulse Width Option (Variable output pulse width protocol conveys rotational speed and relative direction) (W option)		Speed Only Option (Digital square wave output only conveys rotational speed, no relative direction information is available) (O option)	
Forward Pulse, $t_{W(FWD)}$, Rotation Direction	Target movement from pin 1 to pin 3 (F Option)		Target movement from pin 3 to pin 1 (R Option)	
Output Pulse Location	Pulse in middle of the tooth with ferromagnetic target or rising mechanical edge (decided by M1 or M2 option) (N Option)		Pulse in middle of the valley with ferromagnetic target or falling mechanical edge (decided by M1 or M2 option) (S Option)	
	Pulse sent in the middle of the target feature (valley or tooth decided by option N or S) (Option M1)		Pulse sent on the mechanical edge (rising or falling mechanical edge decided by option N or S) (Option M2)	
Typical Forward Pulse Width, $t_{W(FWD)}$	22.5 μ s (F1 Option)		45 μ s (F2 Option)	
Typical Reverse Pulse Width, $t_{W(REV)}$	45 μ s (R1 Option)	90 μ s (R2 Option)	135 μ s (R3 Option)	180 μ s (R4 Option)
Typical Fall Time (with $V_{PU} = 5$ V and $R_{PU} = 1$ k Ω)	3 μ s (T1 option)	6 μ s (T2 option)	1 μ s (T3 option)	2 μ s (T4 option)
Target Profiling Diagnostics	Target profile Diagnostics enabled (D option)		Target profile Diagnostics not available (NA)	
ASIL Protocol	ASIL enabled with Open Short Detection enabled (1 V / 4 V Output, A Option)		ASIL enabled with Open Short Detection disabled (0 V / 5 V Output, B Option)	
			ASIL disabled (NA)	

*Not all combinations are available. Contact Allegro sales for pricing and availability of custom programming options.

SELECTION GUIDE

Part Number	Package	Packing
ATS16951PSMGTN-WFNM2F2R2T1-D-B	3-pin SIP with NiPdAu leadframe plating	Tape and reel, 800 pieces per 13-inch reel
ATS16951PSMGTN-WFNM2F2R2T1-D-A		
ATS16951PSMGTN-WFNM2F2R2T1-D		



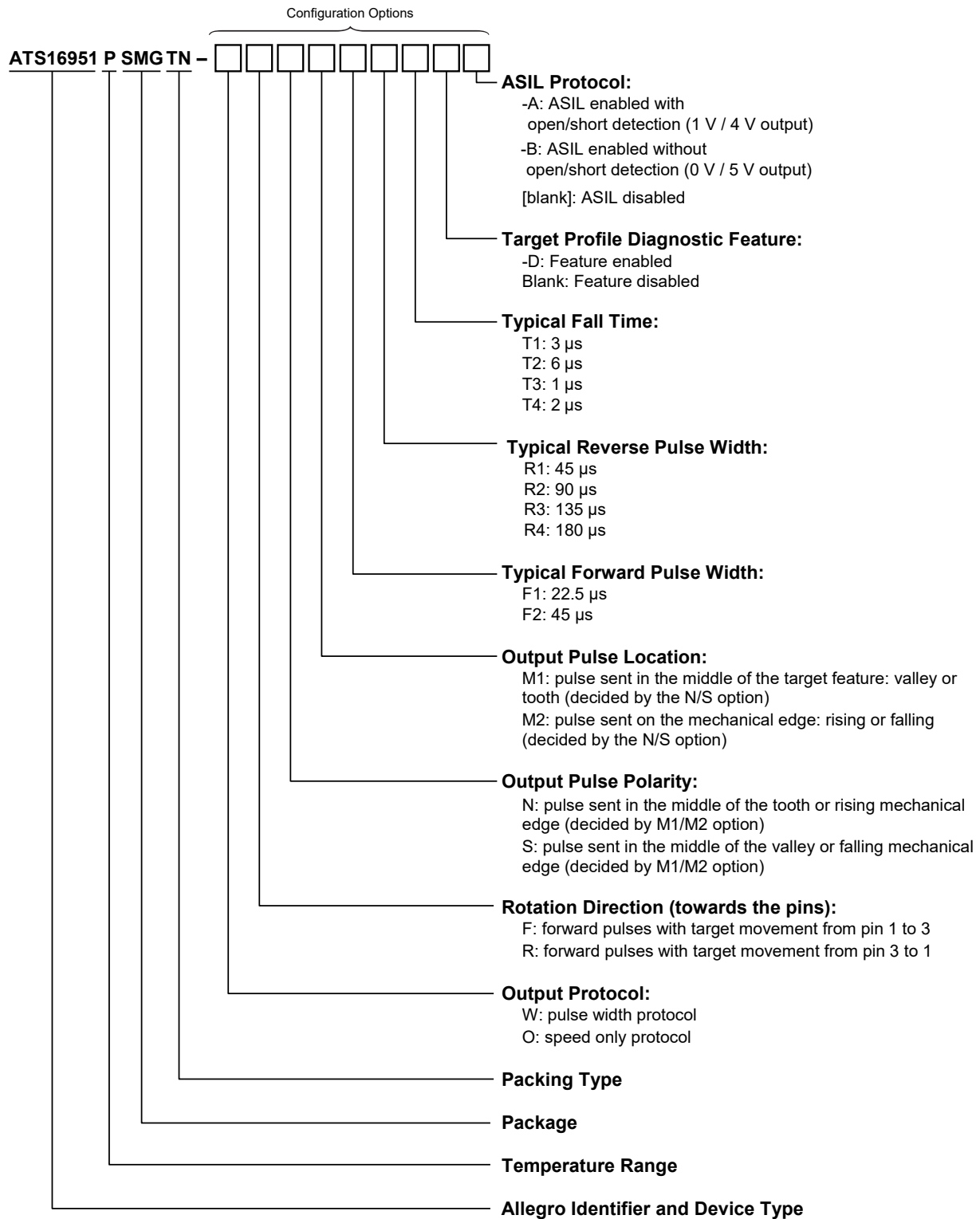

ABSOLUTE MAXIMUM RATINGS

Characteristic	Symbol	Notes	Rating	Unit
Supply Voltage	V_{CC}		26.5	V
Output Voltage	V_{PU}		26.5	V
Reverse Supply Voltage	V_{RCC}		-18	V
Reverse Supply Current	I_{RCC}		50	mA
Reverse Output Voltage	V_{ROUT}		-0.5	V
Output Sink Current	I_{OUT}		25	mA
Operating Ambient Temperature	T_A	Range P	-40 to 160	°C
Maximum Junction Temperature	$T_{J(max)}$		175	°C
Storage Temperature	T_{stg}		-65 to 170	°C
Applied Magnetic Flux Density	B	In any direction	500	G

INTERNAL DISCRETE COMPONENT RATINGS

Symbol	Characteristic	Rating	Unit
C_{SUPPLY}	Nominal Capacitance	220	nF
C_{OUT}	Nominal Capacitance	2.2	nF
R_{SUPPLY}	Nominal Resistance	33	Ω
R_{OUT}	Nominal Resistance	20	Ω

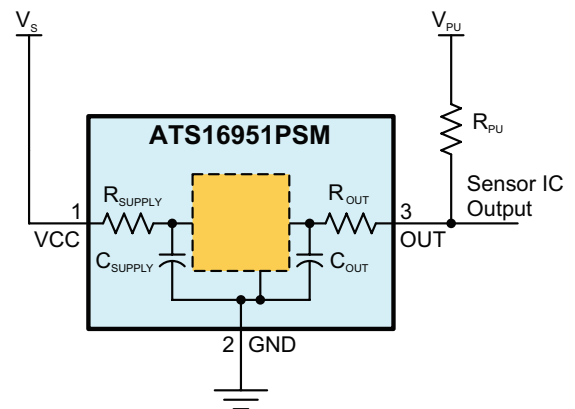

Figure 2: Typical Application Circuit

PINOUT LIST

Number	Name	Function
1	VCC	Supply voltage
2	GND	Ground
3	OUT	Device output

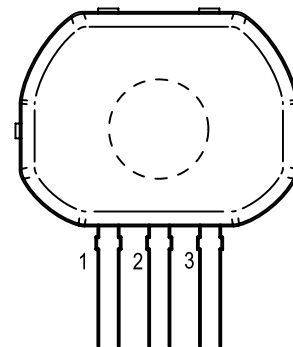

Figure 3: Pinout Diagram

OPERATING CHARACTERISTICS: Valid throughout full operating and temperature ranges; using Reference Target 60+2, unless otherwise noted

Characteristics	Symbol	Test Conditions	Min.	Typ.	Max.	Unit	
ELECTRICAL CHARACTERISTICS							
Supply Voltage	V_{CC}	Operating, $T_J < T_{J(max)}$	4.5	–	24	V	
Supply Current	I_{CC}		–	10	14	mA	
Reverse Supply Current	I_{RCC}	$V_{CC} = -18\text{ V}$	-14	–	–	mA	
OUTPUT STAGE							
ASIL or Open/Short Detection Disabled (ASIL option -B or [blank])	$V_{OUT(SAT)}$	$I_{OUT} = 10\text{ mA}$	–	300	500	mV	
		$I_{OUT} = 20\text{ mA}$	–	600	950	mV	
Output Leakage Current, ASIL Disabled	$I_{OUT(OFF)}$	$V_{OUT} = 18\text{ V}$, Output = HIGH	–	–	10	μA	
ASIL and Open/Short Detection Enabled (ASIL option -A)	$V_{OUT(LOW)}$	$4.75\text{ V} < V_{PU} < 5.25\text{ V}$, $1.455\text{ k}\Omega < R_{PU} < 3.399\text{ k}\Omega$ [1]	500	1000	1500	mV	
	$V_{OUT(HIGH)}$	$4.75\text{ V} < V_{PU} < 5.25\text{ V}$, $1.455\text{ k}\Omega < R_{PU} < 3.399\text{ k}\Omega$	3500	4000	4500	mV	
Output Current Limit	$I_{OUT(LIM)}$	$V_{OUT} = 12\text{ V}$, $T_J < T_{J(max)}$	30	60	80	mA	
Output ASIL Safe State	$V_{OUT(SAFE)}$	See Figure 11; $I_{OUT} < 10\text{ mA}$	–	–	499	mV	
Output ASIL Safe State Reset Timeout	$t_{W(ASIL_safe)}$	See Figure 11	–	5	–	ms	
POWER-ON CHARACTERISTICS							
Power-On State	POS	Connected as in Figure 2	output off (high voltage)			–	
Power-On Time	t_{PO}	$f_{OP} < 100\text{ Hz}$, time from $V_{CC} > V_{CC(MIN)}$ to when IC enters Calibration mode	–	–	1	ms	
OUTPUT PULSE CHARACTERISTICS							
Pulse Width [2]	$t_{W(CAL)}$	During calibration; $R_{PU} = 900\ \Omega$ to $1.1\text{ k}\Omega$; $C_{OUT} = 2.2\text{ nF}$ in package		–	$t_{W(FWD)}$	–	μs
		$t_{W(FWD)}$	Forward running mode; $R_{PU} = 900\ \Omega$ to $1.1\text{ k}\Omega$; $C_{OUT} = 2.2\text{ nF}$ in package	Option F2	39.5	45	50.5
	Option F1			19.3	22.5	25.7	μs
	$t_{W(REV)}$	Reverse running mode; $R_{PU} = 900\ \Omega$ to $1.1\text{ k}\Omega$; $C_{OUT} = 2.2\text{ nF}$ in package	Option R2	80	90	100	μs
			Option R3	120.5	135	149.5	μs
			Option R4	153	180	207	μs
Minimum Separation Between Consecutive Output Pulses	t_{OUTsep}	Option F2	30.6	36	41.4	μs	
		Option F1	15.3	18	20.7	μs	
Output Rise Time	t_r	10%-90%, $R_{PU} = 1\text{ k}\Omega$, $C_{OUT} = 2.2\text{ nF}$	–	10	–	μs	
Output Fall Time	t_f	Measured 90% to 10% of V_{OUT} ; see Figure 4	–	1	–	μs	
		Measured 90% to 10% of V_{OUT} ; $R_{PU} = 1\text{ k}\Omega$, $C_{OUT} = 2.2\text{ nF}$; see Figure 4	$V_{PU} = 5\text{ V}$	1.6	2.3	3.3	μs
			$V_{PU} = 12\text{ V}$	–	3.4	–	μs
Output Delay Time	t_d	1 kHz sinusoidal input signal (fast fall time)	$V_{PU} = 24\text{ V}$	–	5.8	–	μs
				13	17	20	μs

[1] With ASIL ON option, recommended R_{PU} resistor is $1.455\text{ k}\Omega < V_{PU} < 3.399\text{ k}\Omega$.

[2] Pulse widths measured at 50% threshold on both rising and falling edges.

OPERATING CHARACTERISTICS (continued): Valid throughout full operating and temperature ranges; using Reference Target 60+2, unless otherwise noted

Characteristics	Symbol	Note	Min.	Typ.	Max.	Unit	
FUNCTIONAL CHARACTERISTICS							
Switchpoint	$V_{PROC(ST)}$	Speed Channel, Standard target programmable option; see Figure 6	45	50	55	$\%V_{pk-pk}$	
Internal Hysteresis	$V_{PROC(hys)}$	Speed Channel, one-sided; see Figure 6	–	12.5	–	$\%V_{pk-pk}$	
Input LPF Frequency	BW	Multi-pole, –3 dB point	–	20	–	kHz	
Signal Variation		$B_{SEQ(min)} / B_{SEQ(max)}$, does not include Signature Region; see Figure 7	0.5	–	–	–	
		$B_{SEQ(n)} / B_{SEQ(n+1)}$; see Figure 7	0.9	–	1.1	–	
Signature Amplification Ratio		$B_{SEQ(sig)} / B_{SEQ}$ of feature directly before signature region; see Figure 7	0.8	–	2.0	–	
Operating Frequency (input frequency f_{IN})	f_{FWD}	Correct speed information, forward rotation	0	–	10	kHz	
	f_{REV}	Correct speed information, reverse rotation	Option R1	0	–	10	kHz
			Option R2	0	–	7	kHz
			Option R3	0	–	5	kHz
PERFORMANCE CHARACTERISTICS							
Absolute Phase Error During Calibration			$-0.5 \times T_{TARGET}$	–	$0.5 \times T_{TARGET}$	–	
Air Gap Range	AG	Switching in the middle of Tooth or Valley with direction detection (based on Reference 60+2 Target)	1	–	3	mm	
		Switching on Edges with direction detection, or Speed only mode (based on Reference 60+2 Target)	1	–	3.5	mm	
Jitter ^[3]		Switching in the middle of Tooth or Valley; Sinusoidal input signal with 6-degree period; $f_{IN} = 1000$ Hz; 3-sigma, 1-3 mm air gap range	–	–	± 0.025	degrees	
		Switching on Edges; Sinusoidal input signal with 6-degree period; $f_{IN} = 1000$ Hz; 3-sigma, 1-3 mm air gap range.	–	–	± 0.015	degrees	
Time to First Output Edge	$t_{OUT(init)}$	After t_{PO} elapses, $f_{IN} < 600$ rpm	–	$1 \times T_{TARGET}$	–	–	
Initial Calibration Interval	CAL_I	After t_{PO} elapses, $f_{IN} < 600$ rpm; No Signature Region encountered	–	–	4	output pulse	
		After t_{PO} elapses, $f_{IN} < 600$ rpm; Signature Region encountered	–	–	9	output pulse	
Missed or Extra Output Pulses in Running Mode	err_{OUT}		–	0	–	output pulse	
Direction Change Recognition	N_{CD}		–	1	–	switch point	
Vibration Tolerance During Calibration			–	–	$4 \times T_{TARGET}$	–	

^[3] The jitter is bench tested with a 60-2 Target, switching in the middle of the tooth.

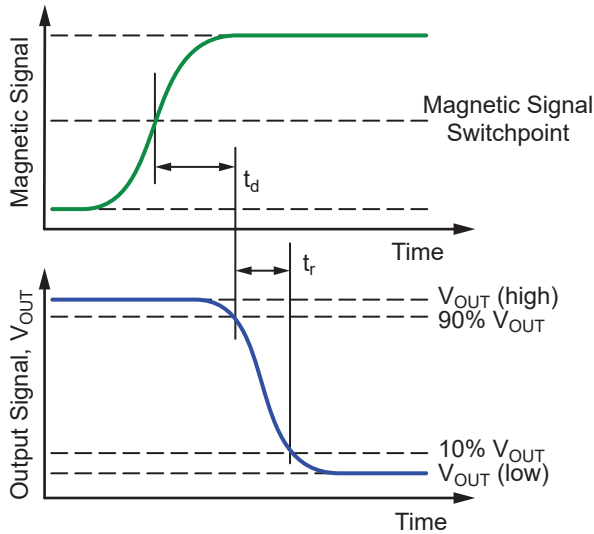
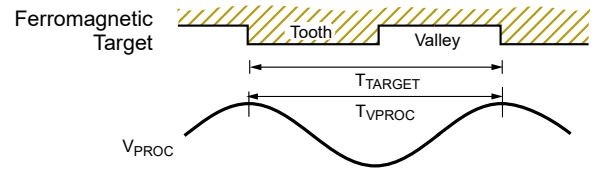

Figure 4: Definition of Output Fall Time and Delay Time



V_{PROC} = the processed analog signal of the sinusoidal magnetic input (per channel)
 T_{TARGET} = period between successive sensed target magnetic edges of the same polarity (for a ferromagnetic target, both rising or both falling mechanical edges)

Figure 5: Definition of T_{TARGET}

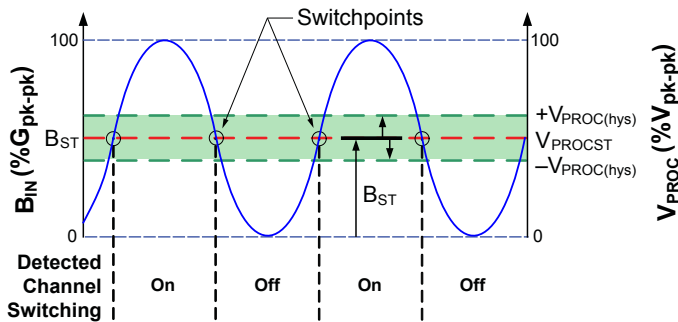

Figure 6: Establishment of Thresholds

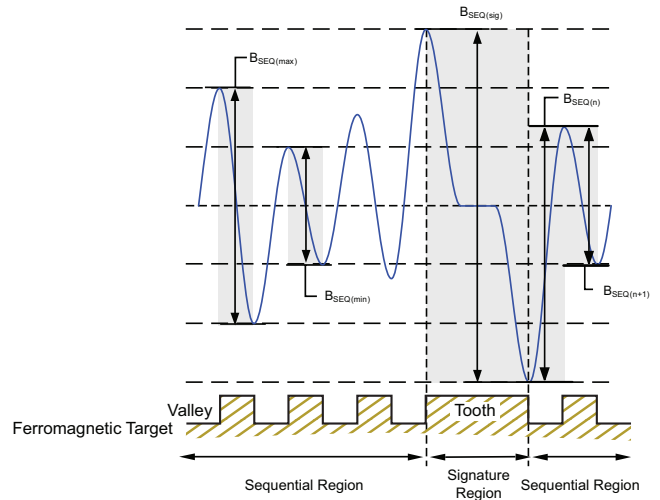
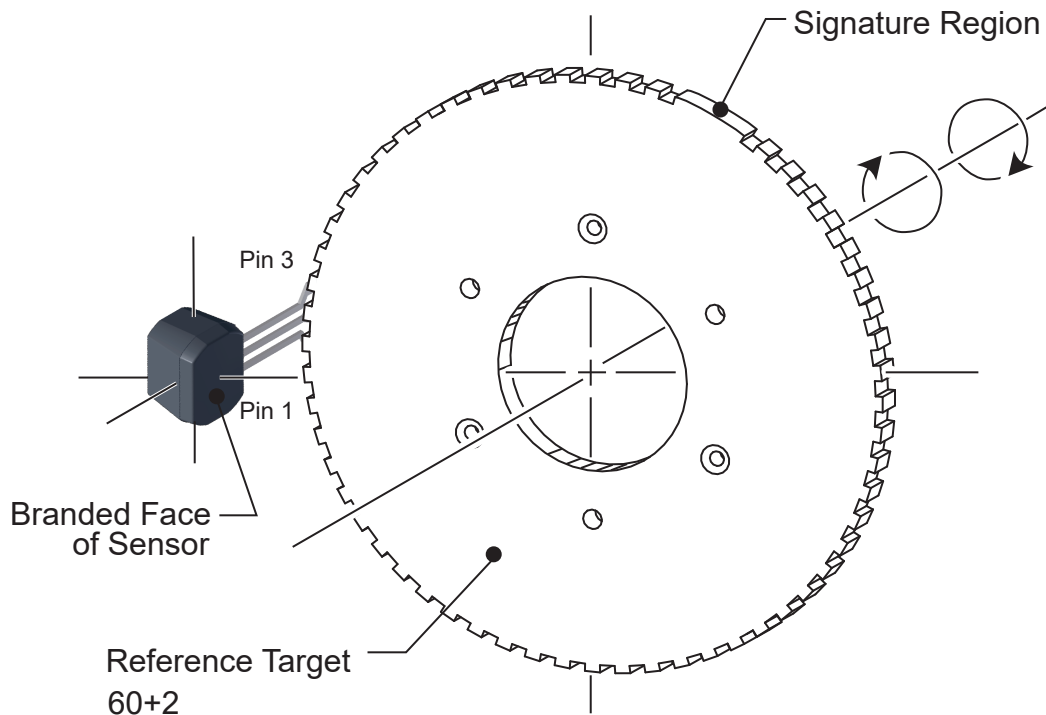

Figure 7: Differential Signature Amplification and Sequential Signal Variation

ALLEGRO REFERENCE TARGET 60+2

Characteristics	Symbol	Test Conditions	Typ.	Units	Symbol Key
Outside Diameter	D_o	Outside diameter of target	120	mm	
Face Width	F	Breadth of tooth, with respect to branded face	6	mm	
Angular Tooth Thickness	t	Length of tooth, with respect to branded face; measured at D_o	3	degrees	
Signature Region Angular Tooth Thickness	t_{SIG}	Length of signature tooth, with respect to branded face; measured at D_o	15	degrees	
Angular Valley Thickness	t_v	Length of valley, with respect to branded face; measured at D_o	3	degrees	
Tooth Whole Depth	h_t		3	mm	
Material		Low Carbon Steel	-	-	



FUNCTIONAL DESCRIPTION

Sensing Technology

The ATS16951PSM contains two GMR bridge elements that provide an electrical output signal containing information regarding target edge position and—if Pulse Width Protocol optioned—direction of rotation.

Target Profiling

After proper power is applied to the ATS16951PSM, digital information—representative of the mechanical features of a rotating target—will be available at the OUT pin. The waveform diagram in Figure 8 shows the translation of the induced magnetic profile to a digital speed and direction signal. The two digital signals are used to determine the location of the switching feature as well as the direction of rotation.

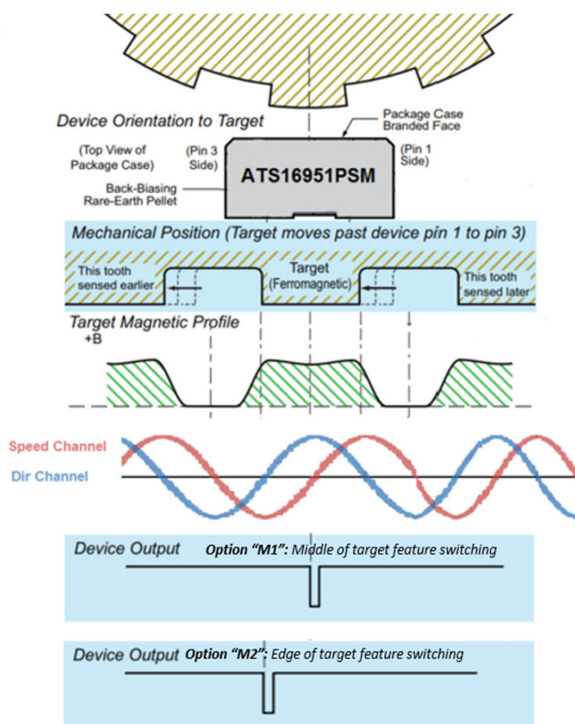

Figure 8: Magnetic Profile

If the device is set on option M1 (switch in the middle of the target feature), the output pulse is based on the 50% of the speed channel.

If the device is set on option M2 (switch on the mechanical edge of the target), the output pulse is based on the 50% of the Dir channel.

Switch Points

The ATS16951PSM switch points are established dynamically as a percentage of the internal V_{PROC} signal amplitude (see Figure 5) to minimize the signal shift effect. This is accomplished by independently tracking the speed and direction peaks of each V_{PROC} channel, where the switching thresholds are established at fixed percentages of the two tracking signals.

Output switching threshold percentage on the speed channel is programmable to ensure the most accurate and consistent output switching. Additionally, the dynamic switch point thresholds allow the ATS16951PSM to properly detect direction of rotation when used with targets containing signature regions. A 50% threshold is recommended for standard crank targets, while the other programmable options allow for functionality on targets with different mechanical geometries.

Sensor Output Protocol

If Pulse Width Protocol optioned, the ATS16951PSM compares the relative amplitude values of the two GMR bridges to determine which direction the target is rotating. The direction of rotation is then communicated through the output pulse width. While in calibration mode, direction information is not available. As a result of this, forward output pulses ($t_{W(FWD)}$) are always given, independent of the true target rotation direction.

If speed only is programmed (Option O), no direction information is available. Only forward output pulses ($t_{W(FWD)}$) are produced.

NOTE: For proper functionality, the output must be programmed such that the signature region is a non-switching feature (see Application Information section).

Forward Pulse Rotation Direction

The ATS16951PSM can be programmed such that the output will provide forward pulses ($t_{W(FWD)}$) when the target rotation is from pin 1 to pin 3 (Option F) or from pin 3 to pin 1 (Option R). This is illustrated in Figure 9 with the arrow on the target indicating direction of rotation.

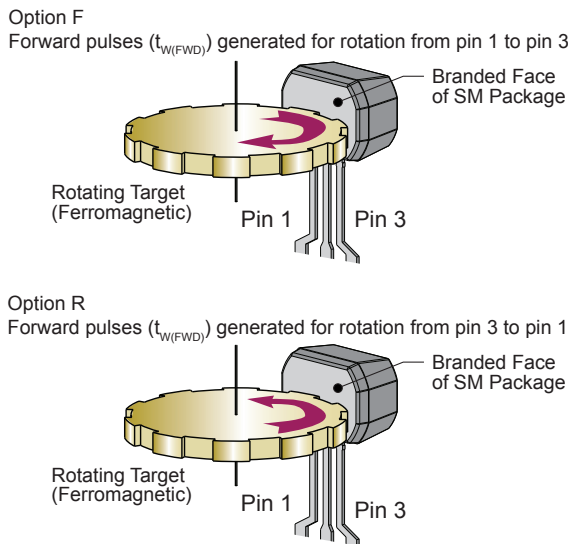

Figure 9: Rotation Direction Definition

Pulse Occurrence Location

The output pulse can be programmed to occur at the target mechanical features of either polarity, i.e. the output pulse can be programmed to occur at the center of a tooth (Option N) or at the center of a valley (Option S) with a ferromagnetic target. The output pulse can also be programmed to occur at the mechanical edge of the target (Option M).

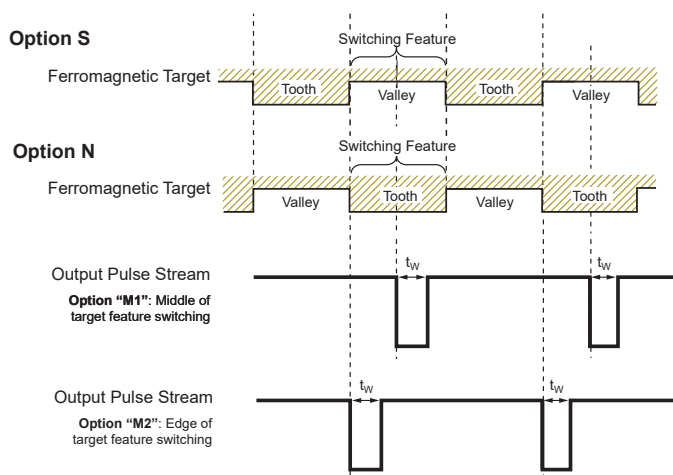

Figure 10: Output Pulse Location

Operating Modes

STARTUP HYSTERESIS

The ATS16951PSM powers up into a startup hysteresis mode and internally senses the magnetic profile of the target. This operating mode is used to ensure the measured magnetic signal amplitude exceeds the minimum signal amplitude (lockout) for the ATS16951PSM algorithm to function properly. A forward pulse ($t_{W(FWD)}$) is given if the magnetic signal amplitude meets the minimum requirements and is powered on over a switching feature.

CALIBRATION MODE

Once the magnetic signal amplitude exceeds the minimum magnetic signal requirements, the ATS16951PSM enters calibration mode. The calibration period allows the internal signal tracking algorithms to properly acquire the magnetic signals.

While in calibration mode, direction information is not available. As a result of this, only forward output pulses ($t_{W(FWD)}$) are given on speed channel switch point crossings, independent of target rotation direction. This pulse width is programmable to meet specific application requirements (see Programmable Options table).

The calibration mode is considered complete when the correct direction information is given. As defined in the Operating Characteristics table, the calibration time (CAL_1) can be up to 4 periods (or 9 if the startup occurs at the signature region).

RUNNING MODE

After calibration is complete, the target's relative rotation direction is known and available. This information is communicated through the variable pulse-width protocol. Forward rotation is indicated with pulses of width $t_{W(FWD)}$ and reverse rotation is indicated with pulses of width $t_{W(REV)}$. The width of the forward pulse ($t_{W(FWD)}$) and the reverse pulse ($t_{W(REV)}$) can be programmed for application-specific performance optimization, (see Programmable Options table). Additionally, see the Forward Pulse Rotation Detection section for a description of the target's relative direction of rotation.

In running mode, signal tracking algorithms are employed, allowing the ATS16951PSM to track signal drift from temperature changes, and target variations such as tooth-to-tooth variation and runout, while still maintaining high output switching accuracy.

The ATS16951PSM provides vibration tolerance during calibration and running mode. The vibration recovery algorithm allows the part to recover within a few features.

The ATS16951PSM also contains a special smart optimization

method. If chosen to be activated, during the first or second revolution, the device will self-adapt to improve the signal and achieve better performances. During this self-adaptation period, only the edge accuracy might be slightly affected. Once this period is finished, the device will function with its highest performances for accuracy and repeatability.

STOP & GO MODE

In certain engine management applications, it is possible for large temperature changes to occur while the target is stationary. These temperature changes can affect the differential magnetic signals. The Stop & Go algorithm compensates for such shifts in the processed signal. Once normal rotation resumes, the part will return to running mode.

Diagnostic Capability

When diagnostic functionality is activated, the device continuously monitors itself, from the signal chain to output levels, and reports a fault by driving the output to the safe state ($V_{OUT(SAFE)}$) for a period of time defined by $t_{w(ASIL_safe)}$. After this period of time, the device will attempt to recover by self-reset. In case of permanent detectable failure, the sequence is repeated indefinitely (see Figure 11).

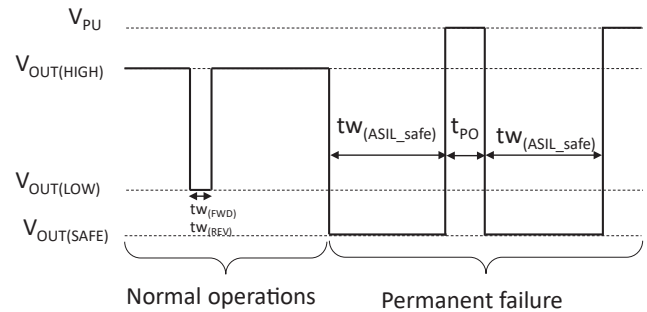

Figure 11: ASIL Output Behavior (ASIL Option -A)

Note: For ASIL option -B, $V_{OUT(HIGH)}$ and $V_{OUT(LOW)}$ would be at the same level as V_{PU} or $V_{OUT(SAFE)}$

The ATS16951PSM is programmable to allow for system failure detection such as Output Pin short circuit or open wire. In such cases, output goes above or below normal operating voltage range ($V_{OUT(LOW)}$ or $V_{OUT(HIGH)}$), depending on the failure mode (ASIL option -A).

Target Profile Diagnostics

Target Profile Diagnostics allows customers to characterize a gear target during manufacturing, and to detect any subtle gear tooth anomalies that may exist before an engine is installed into the vehicle, thus saving cost. It has the potential to reduce warranty returns, thus increasing customer satisfaction.

APPLICATION INFORMATION

Power Supply Protection

The ATS16951PSM contains an on-chip regulator and can operate across a wide supply voltage range. With only a single pull-up resistor necessary for proper operation, as shown in Figure 2, design time and assembly costs are reduced for most applications. Contact Allegro MicroSystems for information on EMC specification compliance.

Target Design

The ATS16951PSM is designed to provide highly accurate switching at each switching feature detected, including switching at the first switching feature after power-on, as well as at the first switching feature after a reversal in the direction of target rotation. Contact Allegro for support on target design.

POWER DERATING

The device must operate below the rated maximum junction temperature of the device, $T_{J(max)}$. Under certain peak operating conditions, reliable operation may require power supply voltage derating and/or improved heat dissipation to ensure proper operation. This section presents a procedure for correlating factors that affect the operating junction temperature T_J . (Thermal data is also available on the Allegro MicroSystems website.)

The Package Thermal Resistance, $R_{\theta JA}$, is a figure of merit summarizing the ability of the package to dissipate heat from the junction (die), through all paths, to the ambient air. Its primary component is the Effective Thermal Conductivity, K , of the printed circuit board, including adjacent devices and traces. Radiation from the die through the device case, $R_{\theta JC}$, is a relatively small component of $R_{\theta JA}$. Ambient air temperature, T_A , and air motion are significant external factors, damped by overmolding.

The effect of varying power levels (Power Dissipation, P_D), can be estimated. The following formulas represent the fundamental relationships used to estimate T_J , at P_D .

$$P_D = V_{IN} \times I_{IN} \quad (1)$$

$$\Delta T = P_D \times R_{\theta JA} \quad (2)$$

$$T_J = T_A + \Delta T \quad (3)$$

For example, given common conditions such as: $T_A = 25^\circ\text{C}$, $V_{CC} = 12\text{ V}$, $I_{CC} = 7\text{ mA}$, and $R_{\theta JA} = 147^\circ\text{C/W}$, then:

$$P_D = V_{CC} \times I_{CC} = 12\text{ V} \times 7\text{ mA} = 84\text{ mW}$$

$$\Delta T = P_D \times R_{\theta JA} = 84\text{ mW} \times 147^\circ\text{C/W} = 12.3^\circ\text{C}$$

$$T_J = T_A + \Delta T = 25^\circ\text{C} + 12.3^\circ\text{C} = 37.3^\circ\text{C}$$

A worst-case estimate, $P_{D(max)}$, represents the maximum allowable power level ($V_{CC(max)}$, $I_{CC(max)}$), without exceeding $T_{J(max)}$, at a selected $R_{\theta JA}$ and T_A .

Example:

Reliability for V_{CC} at $T_A = 160^\circ\text{C}$, estimated values based on package SM, using single layer PCB.

Observe the worst-case ratings for the device, specifically:

$$R_{\theta JA} = 147^\circ\text{C/W}, T_{J(max)} = 175^\circ\text{C}, V_{CC(absmax)} = 24\text{ V}, \text{ and } I_{CC} = 14\text{ mA}.$$

Calculate the maximum allowable power level, $P_{D(max)}$. First, solve equation 3 for $\Delta T_{(max)}$, the specified $T_{J(max)}$, and T_A :

$$\Delta T_{(max)} = T_{J(max)} - T_A = 175^\circ\text{C} - 160^\circ\text{C} = 15^\circ\text{C}$$

This provides the allowable increase to T_J resulting from internal power dissipation. Then, solve equation 2 for $P_{D(max)}$:

$$P_{D(max)} = \Delta T_{(max)} \div R_{\theta JA} = 15^\circ\text{C} \div 147^\circ\text{C/W} = 102\text{ mW}$$

Finally, solve equation 1 with respect to supply voltage:

$$V_{CC(est)} = P_{D(max)} \div I_{CC} = 102\text{ mW} \div 14\text{ mA} = 7.3\text{ V}$$

The result indicates that, at T_A , the application and device can dissipate adequate amounts of heat at voltages $\leq V_{CC(est)}$.

Compare $V_{CC(est)}$ to $V_{CC(max)}$. If $V_{CC(est)} \leq V_{CC(max)}$, then reliable operation between $V_{CC(est)}$ and $V_{CC(max)}$ requires enhanced $R_{\theta JA}$. If $V_{CC(est)} \geq V_{CC(max)}$, then operation between $V_{CC(est)}$ and $V_{CC(max)}$ is reliable under these conditions.

THERMAL CHARACTERISTICS: May require derating at maximum conditions

Characteristic	Symbol	Test Conditions*	Value	Unit
Package Thermal Resistance	$R_{\theta JA}$	1-layer PCB with copper limited to solder pads	147	$^\circ\text{C/W}$

*Additional thermal information available on the Allegro website.

Power Derating Curve

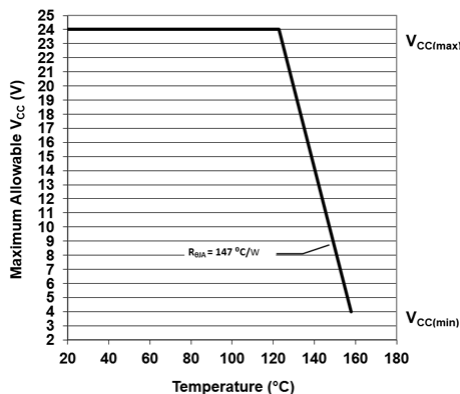

Power Dissipation versus Ambient Temperature

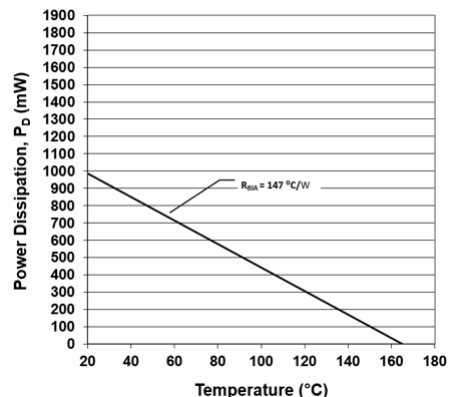

Package SM, 3-Pin SIP

For Reference Only – Not for Tooling Use

(Reference DWG-0000417, Rev. 3)

Dimensions in Millimeters – NOT TO SCALE

Dimensions exclusive of mold flash, gate burrs, and dambar protrusions
Exact case and lead configuration at supplier discretion within limits shown

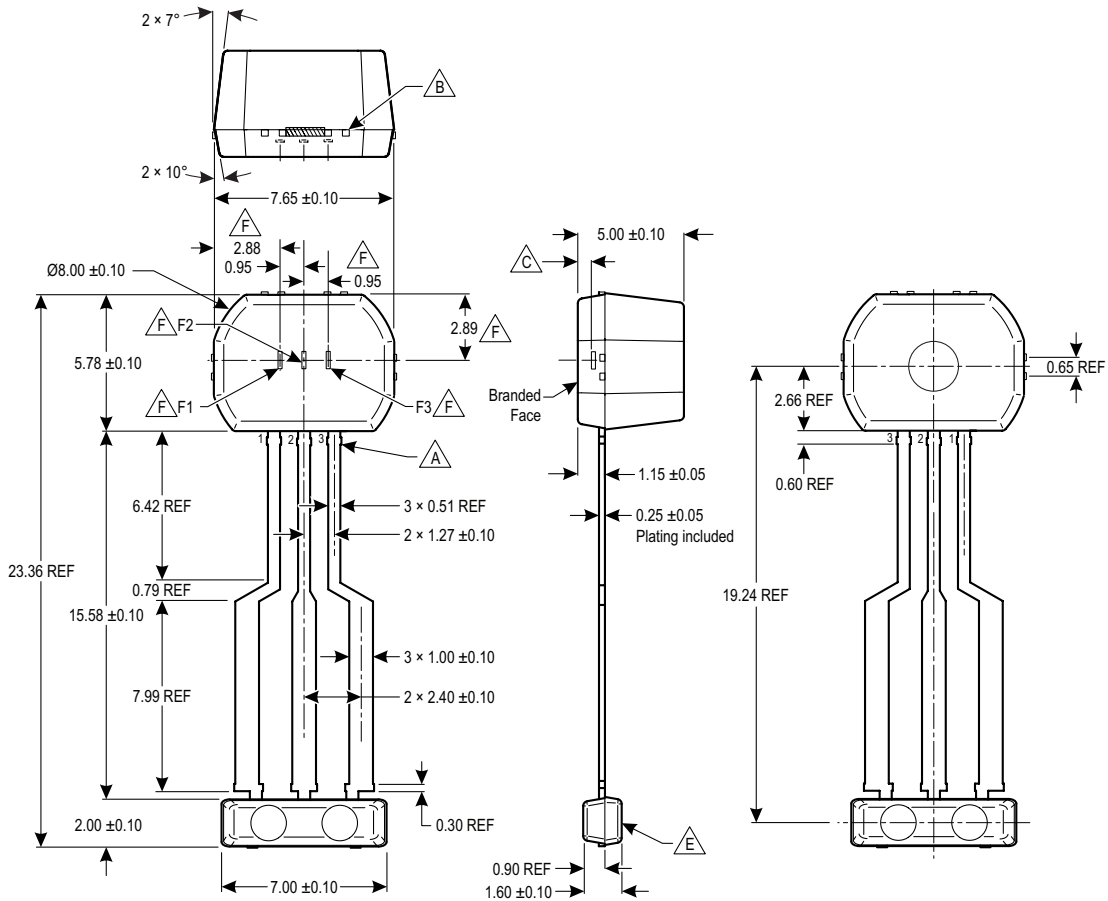

- A** Dambar removal protrusion (12x)
- B** Gate and tie bar burr area
- C** Active Area Depth 0.60 ± 0.05 mm
- D** Branding scale and appearance at supplier discretion
- E** Molded lead bar for preventing damage to leads during shipment
- F** GMR elements (F1, F2, and F3), not to scale

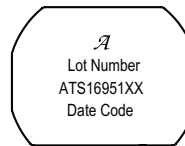

D Standard Branding Reference View

Lines 1, 2, 3, 4: Up to 10 characters, centered

- Line 1: Logo A
- Line 2: Characters 5, 6, 7, 8, 9, 10, 11 of Assembly Lot Number
- Line 3: Part Number:
3 character prefix (ATS),
5 digit part number (16951),
0-2 character part variant (XX).
Example: ATS16951B
- Line 4: 4 digit Date Code

Revision History

Number	Date	Description
–	December 10, 2021	Initial release
1	December 17, 2021	Updated document title

Copyright 2021, Allegro MicroSystems.

Allegro MicroSystems reserves the right to make, from time to time, such departures from the detail specifications as may be required to permit improvements in the performance, reliability, or manufacturability of its products. Before placing an order, the user is cautioned to verify that the information being relied upon is current.

Allegro's products are not to be used in any devices or systems, including but not limited to life support devices or systems, in which a failure of Allegro's product can reasonably be expected to cause bodily harm.

The information included herein is believed to be accurate and reliable. However, Allegro MicroSystems assumes no responsibility for its use; nor for any infringement of patents or other rights of third parties which may result from its use.

Copies of this document are considered uncontrolled documents.

For the latest version of this document, visit our website:

www.allegromicro.com